

# Data Structures and Algorithms

Muchang Bahng

Spring 2024

## Contents

<b>1</b>	<b>Array-Based Data Structures</b>	<b>6</b>
1.1	Arrays and Lists . . . . .	6
1.2	Linked List and Iterators . . . . .	10
1.3	Stacks . . . . .	14
1.4	Queues . . . . .	15
<b>2</b>	<b>Hash-Based Data Structures</b>	<b>17</b>
2.1	Hashing . . . . .	17
2.2	Set . . . . .	19
2.3	Map . . . . .	19
<b>3</b>	<b>Graph-Based Data Structures</b>	<b>21</b>
3.1	Graphs . . . . .	21
3.2	Graph Traversal with DFS/BFS . . . . .	23
3.3	Trees . . . . .	28
3.3.1	Binary Trees . . . . .	31
3.4	Heaps . . . . .	33
3.5	Binary Search Trees . . . . .	36
3.6	Tries . . . . .	38
<b>4</b>	<b>Brute Force Algorithms</b>	<b>39</b>
4.1	Basic Arithmetic . . . . .	39
4.2	Lists . . . . .	42
4.3	Stack, Queues, Heaps . . . . .	43
4.4	Cryptography . . . . .	43
4.5	Matrix Operations . . . . .	45
<b>5</b>	<b>Greedy Algorithms</b>	<b>47</b>
5.1	Huffman Coding . . . . .	51
<b>6</b>	<b>Divide and Conquer</b>	<b>54</b>
6.1	Recursion and Recurrence . . . . .	54
6.2	Merge Sort and Counting Inversions . . . . .	58
6.3	Selection and Quick Sort . . . . .	60
6.4	Closest Pair of Points . . . . .	61
6.5	Multiplication . . . . .	63
6.5.1	Karatsuba Algorithm . . . . .	63
6.5.2	Strassen Algorithm . . . . .	63
6.6	Polynomial Multiplication with Fast Fourier Transform . . . . .	64
<b>7</b>	<b>Graph Algorithms</b>	<b>67</b>

---

7.1	Directed Acyclic Graphs and Topological Sorting . . . . .	67
7.2	Bipartite Graphs . . . . .	70
7.3	Strongly Connected Graphs . . . . .	72
7.4	Shortest Positive Path with Dijkstra's . . . . .	73
7.5	Negative Weighted Graphs with Bellman Ford . . . . .	76
7.5.1	All Pairs Shortest Graphs with Floyd Warshall . . . . .	80
7.6	Minimum Spanning Trees . . . . .	80
7.6.1	Prim's Algorithm with Cuts . . . . .	80
7.6.2	Kruskal's Algorithm . . . . .	84
7.6.3	Applications . . . . .	88
7.7	Maximum Flows and Minimum Cuts . . . . .	89
7.8	Exercises . . . . .	98
<b>8</b>	<b>Dynamic Programming</b>	<b>104</b>
8.1	Longest Increasing Subsequence . . . . .	105
8.2	0/1 Knapsack . . . . .	107
8.3	Line Breaking . . . . .	109
8.4	Bellman Ford Revisited . . . . .	112
<b>9</b>	<b>Probabilistic Algorithms</b>	<b>114</b>
9.1	Primality Testing . . . . .	114
<b>10</b>	<b>Efficiency</b>	<b>115</b>
10.1	Classification of Decision Problems . . . . .	115
10.2	Proving NP-Hardness . . . . .	116
10.3	Logic and Satisfiability . . . . .	117
10.4	Graph Problems . . . . .	119
10.4.1	Maximum Independent Set . . . . .	119
10.4.2	Minimum Vertex Cover . . . . .	120
10.4.3	Maximum Clique . . . . .	121
10.4.4	Hamiltonian Paths . . . . .	122
10.4.5	Euler Paths . . . . .	123
10.4.6	Longest Path . . . . .	123
10.4.7	Graph Coloring . . . . .	123
10.5	Subset Sum . . . . .	124
<b>11</b>	<b>Streaming Algorithms</b>	<b>126</b>
<b>12</b>	<b>Linear Programming</b>	<b>127</b>

A course on the study of data structures and algorithms. We can start off by defining what these two terms mean.

### Definition 0.1 (Data Structure)

A **data structure**  $\mathcal{D}$  is an object that can store some amount of data. The **size**  $|\mathcal{D}|$  of the data structure is a finite collection of nonnegative integers used to characterize the number of values that it stores.<sup>a</sup>

<sup>a</sup>For example, the size of an array is  $N$ , but the size of a graph  $G = (V, E)$  is characterized by two numbers  $(N, M)$  representing the number of vertices and edges in the graph.

### Definition 0.2 (Algorithm)

Given a data structure  $\mathcal{D}$ , an **algorithm**  $\mathcal{A}(\mathcal{D})$  is a procedure on the data structure for correctly solving a mathematical problem in a finite number of steps. There are generally two paradigms on how algorithms work:

1. *Iterative.* Where  $\mathcal{A}(\mathcal{D})$  is called that processes  $\mathcal{D}$ .
2. *Recursive.*  $\mathcal{A}(\mathcal{D})$  calls the same algorithm on a finite number of processed (usually smaller) data structures  $\mathcal{A}(\mathcal{D}_i)$ . After these recursive calls, the base algorithm may then postprocess the outputs to generate a new output. The general way to do this is to consider the base case of  $\mathcal{D}$  when  $\mathcal{A}(\mathcal{D})$  should not make any more recursive calls. Then assuming that the algorithm runs correctly for some input, determine what we should do with the recursive call.<sup>a</sup>

The **runtime** of an algorithm is a function  $T(|\mathcal{D}|)$  with respect to the size of the dataset that outputs the number of steps it takes to complete this algorithm.<sup>b,c</sup>

<sup>a</sup>We must ensure that every recursive call gets closer to the base case, or this will never end in a finite number of steps and is thus not an algorithm.

<sup>b</sup>The reason I don't put time as the output is that time can refer to many things, such as physical time or the number of flops, which may differ depending on what computer you run an algorithm on. The number of steps is constant, and informally these refer to *atomic* steps that cannot be decomposed further into substeps.

<sup>c</sup>There are two notions of runtime here. We can compare  $f$  and  $g$  with respect to the *value*  $N$  of the input, or we can compare them with respect to the *number of bits*  $n$  in the input. While we mostly use the complexity w.r.t. the value in these notes, we should be aware for certain (especially low-level operations), the bit complexity is also important, which will be focused on in my advanced algorithms notes.

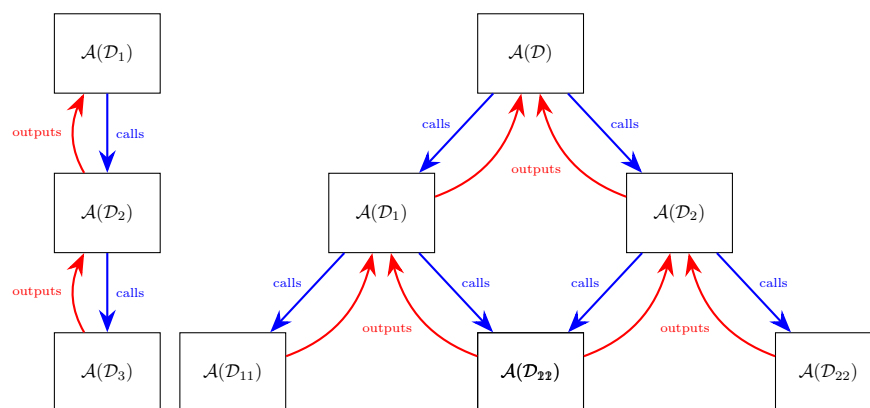

Figure 1: Linear recursion on the left. Binary tree recursion on the right.

This is a pretty loose definition of data structure and algorithms, but the point I want to make is that data structures are a fundamental object of study, and to interact with these data structures, we can use algorithms (hence I put algorithms as taking a data structure as an input). The whole purpose of having

different data structures is that we can construct efficient algorithms that can interact with them in different ways, e.g. getter/setter algorithms. Therefore, this is sort of like the chicken and egg situation. Algorithms act on data structures, but data structures are inspired by algorithms.

Clearly, the runtime is extremely important when comparing the efficiency of different algorithms. To formalize this comparison, we need the power of mathematical analysis to analyze the asymptotic behavior between two functions.

### Definition 0.3 (Complexity)

Given two positive functions  $f, g$ ,

1.  $f = O(g)$  if  $f/g$  is bounded.<sup>a</sup>
2.  $f = \Omega(g)$  if  $g/f$  is bounded, i.e.  $g = O(f)$ .
3.  $f = \Theta(g)$  if  $f = O(g)$  and  $g = O(f)$ .

Recalling analysis, if we want to figure out the complexity of two positive functions  $f, g$ ,<sup>b</sup> we can simply take the limit.

$$\lim_{x \rightarrow +\infty} \frac{f(x)}{g(x)} = \begin{cases} 0 & \implies f = O(g) \\ 0 < x < +\infty & \implies f = \Theta(g) \\ +\infty & \implies f = \Omega(g) \end{cases} \quad (1)$$

<sup>a</sup>Note that it is more accurate to write  $f \in O(g)$ , since we consider  $O(g)$  a class of functions for which the property holds.

<sup>b</sup>These will be positive since the runtime must be positive.

Most of the time, we will have to use L'Hopital's rule to derive these actual limits, but the general trend is  $\log n$  is small,  $\text{poly}(n)$  grows faster,  $\exp(n)$  grows even faster,  $n!$  even faster, and  $n^n$  even faster. Some nice properties follow immediately.

### Theorem 0.1 (Properties)

Some basic properties, which shows very similar properties to a vector space.

1. Transitivity.

$$f = O(g), g = O(h) \implies f = O(h) \quad (2)$$

$$f = \Omega(g), g = \Omega(h) \implies f = \Omega(h) \quad (3)$$

$$f = \Theta(g), g = \Theta(h) \implies f = \Theta(h) \quad (4)$$

$$(5)$$

2. Linearity.

$$f = O(h), g = O(h) \implies f + g = O(h) \quad (6)$$

$$f = \Omega(h), g = \Omega(h) \implies f + g = \Omega(h) \quad (7)$$

$$f = \Theta(h), g = \Theta(h) \implies f + g = \Theta(h) \quad (8)$$

$$(9)$$

### Example 0.1 (Comparing Runtimes)

Compare the following functions.

1.  $f(n) = \log_{10}(n), g(n) = \log_2(n)$ . Since they are different bases, we can write  $f(n) = \log(n)/\log(10)$  and  $g(n) = \log(n)/\log(2)$ . They differ by a constant factor, so  $f = \Theta(g)$ .

2.  $f(n) = (\log n)^{20}, g(n) = n$ . We have

$$\lim_{n \rightarrow \infty} \frac{(\log n)^{20}}{n} = \lim_{n \rightarrow \infty} \frac{20 \cdot (\log n)^{19} \cdot \frac{1}{n}}{1} = \dots = \lim_{n \rightarrow \infty} \frac{20!}{n} = 0 \implies f = O(g) \quad (10)$$

3.  $f(n) = n^{100}, g(n) = 1.01^n$ . We have

$$\lim_{n \rightarrow \infty} \frac{n^{100}}{1.01^n} = \lim_{n \rightarrow \infty} \frac{100n^{99}}{1.01^n \cdot \log(1.01)} = \dots = \lim_{n \rightarrow \infty} \frac{100!}{1.01^n \cdot (\log 1.01)^{100}} = 0 \implies f = O(g) \quad (11)$$

Let's do a slightly more nontrivial example.

### Example 0.2 (Complexity of a Recursive Function)

Given the following algorithm, what is the runtime?

```

1 for i in range(1, n+1):
2     j = 1
3     while j <= i:
4         j = 2 * j

```

Now we can see that for each  $i$ , we will double up to  $\log_2(i)$  times. Therefore summing this all over  $i$  is

$$\sum_{i=1}^n \log_2(i) = \log_2(n!) \leq \log_2(n^n) = n \log_2(n) \quad (12)$$

and so we can see that the runtime is  $O(n \log n)$ . Other ways to do this is to just replace the summation with an integral.<sup>a</sup>

$$\int_1^n \log_2(x) dx = x \log(x) - x \Big|_1^n = n \log(n) - n + 1 = O(n \log n) \quad (13)$$

<sup>a</sup>Need more justification on why this is the case. Mentioned in lecture.

# 1 Array-Based Data Structures

What is the most simple type of data structure? In our daily lives, let's think of how we store data.

1. A sentence consists of a sequence of words or letters.
2. A locker combination is a sequence of integers.
3. Accounting consists of logging a sequence of numbers for one's bank account.

All of these things are sequential, so mathematically we can represent them as sequences. However realistically we cannot have them be infinite like their mathematical analogue, so we work with arrays or lists.

## 1.1 Arrays and Lists

The most simple form of a data structure requires us to fix a length  $n$  of the number of elements it can contain. This is called an *array*.

### Definition 1.1 (Array)

An **array of size**  $n$  is a data structure  $A$  that can contain up to  $n$  elements in a specific order. The element in the  $i$ th index of  $A$  is denoted  $a_i$ , and for most programming languages, we start at the index  $i = 0$ , called **zero-indexing**.<sup>a</sup> So our array would look like

$$A = [a_0, a_1, \dots, a_n] \quad (14)$$

An uninitialized element will be denoted  $a_i = \emptyset$ . We also write  $a_i = A[i]$ .

<sup>a</sup>When we say "first," "second," or "third" element in English, this will mean the elements on the 0th, 1st, and 2nd index, respectively.

Great, so we have established our first data structure. Now we must be able to interact with it. The most elementary operations that we can do on  $A$  is to add an element, remove an element, modify an element. Though this seems trivial at first glance, we must be careful on how the array is *stored*. For example, if we store an array by writing down on a piece of paper, deleting an element (erasing it) would leave a whitespace gap where the original element was. We have to ask ourselves: are we fine with having this whitespace or should we shift the rest of the elements on the right one space to the left? Who even said that we have to shift the right-side elements? If we have deleted the second element, then we can just take the single element at index 0 and shift that one right without having to move the rest of the list.

So there are a lot of nuances to this, and the efficiency of these operations really depend on how the arrays are stored. The question of how to store these lists efficiently will be thoroughly discussed in my architecture notes.

All these algorithms can be thought of as acting on an array  $A$ , denoted  $\mathcal{A}(A)$ . Let's go through them, starting with *retrieval* of an element through a *getter function*.

### Algorithm 1.0 (Retrieval of $i$ th Element)

Retrieval of the element  $a_i$  at the  $i$ th index is  $O(1)$ .

$$[a_0, \dots, a_{i-1}, \emptyset, a_{i+1}, \dots, a_{n-1}] \mapsto a_i \quad (15)$$

The next two—insert and modify—are called *setter functions* since they set an element in array  $A$  to a given value.

**Algorithm 1.0 (Insert Element to Array)**

Insertion of element  $b$  to index  $i$  of array  $A$  refers to replacing an uninitialized variable  $a_i = \emptyset$  with  $b$ . This is  $O(1)$ .

$$[a_0, \dots, a_{i-1}, \emptyset, a_{i+1}, \dots, a_{n-1}] \mapsto [a_0, \dots, a_{i-1}, b, a_{i+1}, \dots, a_{n-1}] \quad (16)$$

**Algorithm 1.0 (Modify Element in Array)**

Modifying the  $i$ th element of array  $A$  refers to replacing an initialized variable  $a_i$  with an element  $b$ . This is  $O(1)$ .

$$[a_1, \dots, a_{i-1}, a_i \neq \emptyset, a_{i+1}, \dots, a_n] \mapsto [a_0, \dots, a_{i-1}, b, a_{i+1}, \dots, a_{n-1}] \quad (17)$$

**Algorithm 1.0 (Contains in Array)**

Given an element  $b$ , if we want to find out whether  $b$  is contained in  $A$ , we must loop through the elements of  $A$  and directly compare  $b$  with  $a_i$ . This is  $O(n)$ .

**Algorithm 1.0 (Remove Element from Array)**

Removing the  $i$ th initialized element  $a_i$  of array  $A$  refers to deleting  $a_i$ , hence making it uninitialized  $a_i = \emptyset$ . This is  $O(1)$ .

$$[a_0, \dots, a_{i-1}, a_i, a_{i+1}, \dots, a_{n-1}] \mapsto [a_0, \dots, a_{i-1}, \emptyset, a_{i+1}, \dots, a_{n-1}] \quad (18)$$

Great, so we have achieved three constant-time methods to interact with this data structure. This is already quite intuitive, since inserting refers to writing a new record, modifying means overwriting a record, and removing means erasing a record. What else can we do? Inspired by our bookkeeping habits, we may want to talk about how many records we have in our array.

**Algorithm 1.0 (Size of Array)**

The size of an array can mean two things.

1. If we want to talk about the number of elements it can store, it is  $n$  by definition and thus getting this is  $O(1)$ .
2. If we want to find the number of initialized elements in  $A$ , then we must manually loop through the elements and see whether each  $a_i$  is  $\emptyset$  or not. This is  $O(n)$ .

While arrays are extremely useful, they may not be so flexible due to their rigid memory requirements. If we make an array of size 10 and find out later that we will need to store more than 10 elements, how should we proceed? An obvious solution is to just create a second array. But this requires us to keep track of multiple arrays for elements that are conceptually part of the same system, so this is untidy. A better alternative is to create a bigger array  $B$ , move all elements of the current array  $A$  into  $B$ , and then just work with  $B$ . This motivates a *list*.<sup>1</sup>

<sup>1</sup>Sometimes in literature, arrays and lists are used interchangeably. ArrayLists are also a term as well! However, in here, I will strictly differentiate arrays and lists.

**Definition 1.2 (List)**

A **list** is a data structure  $L$  that implements an array in the backend but a systematic way to dynamically grow in size. A list must have all of its elements initialized.<sup>a</sup> The **size** of  $L$  refers to the number of initialized elements in  $L$ .

$$L = [] \quad (19)$$

$$L = [1, 2, 3] \quad (20)$$

$$L = [a, c, b, l, p] \quad (21)$$

<sup>a</sup>This also depends on the language/architecture, but we will follow Python's protocol.

Since the add operation depends on the growth of the list, we will introduce growth first. Clearly this growth

**Algorithm 1.0 (Grow Array Size of List)**

Given a list  $L$  with an underlying array of length  $n$ , the grow operator

1. first initializes a list  $\hat{L}$  of size  $f(n) > n$ , and
2. second moves all elements from  $L$  to  $\hat{L}$ , s.t.  $\hat{L}[i] \leftarrow L[i]$  for  $i = 0, \dots, n - 1$ .

For each  $i$ , getting  $L[i]$  is  $O(1)$  and setting  $\hat{L}[i] \leftarrow L[i]$  is also  $O(1)$ . Therefore by looping over  $n$  elements this operation is  $O(n)$ .

Clearly this growth operation is expensive, and we would like to do it a small number of times. A naive approach would be to start with a list of underlying array size 10 and if we decide that we have to add, we can increase the size to 1,000,000. However, this may be wasteful in memory, especially if we later see that we need to store only 11 elements. This is why a slightly more sophisticated growth scheme is preferred.

**Example 1.1 (Some Growth Schemes)**

We present some growth schemes.

1. *Increment by One.* The simplest approach is to increase the array size by 1 each time we need more space. When we have an array of size  $n$  and need to add the  $(n + 1)$ th element, we allocate a new array of size  $n + 1$ , copy all  $n$  elements, and add the new element. This gives sizes

$$1, 2, 3, 4, 5, \dots, n \quad (22)$$

While simple, this is inefficient as it requires  $O(n^2)$  total copy operations to build a list of size  $n$ .

2. *Linear Growth.* We increase the array size by a constant factor  $c$  each time. When we have an array of size  $n$  and need more space, we allocate a new array of size  $n + c$ , where  $c$  is some constant (e.g.,  $c = 10$ ). This gives sizes

$$1, 1 + c, 1 + 2c, 1 + 3c, \dots, 1 + kc \quad (23)$$

This is better than increment by one, but still results in  $O(n^2)$  total copy operations.

3. *Geometric Growth.* We start with a list of size 0 (array size 1). When we have an array size of  $n$  and add the  $n + 1$ th element, we increase the size of the array to  $2n$ . So our scheme gives sizes

$$1, 2, 4, 8, 16, \dots \quad (24)$$

This is how ArrayLists are implemented in Java.

4. *Pseudo-Geometric Growth.* Python uses a formula that increases the array size by approximately  $1/8$  plus  $3/4$  of the current size. When the list has size  $n$ , the new size becomes  $|\hat{L}| = n + (n >> 3) + (n < 9?3 : 6)$ . This gives a sequence like

$$0, 4, 8, 16, 25, 35, 46, 58, 72, 88, \dots \quad (25)$$

which grows slightly slower than pure geometric growth but still maintains amortized  $O(1)$  performance for appends.

This geometric growth is a good tradeoff between performance and memory usage. It never uses more than twice the memory of an array in order to store it. Furthermore, the runtime of a geometric growth pattern is amortized constant time, which means that it is constant when averaged over a long time. This is because the vast majority of these operations are constant time, with a few add operations which require resizing to be longer. But these few ones happen less and less frequently that when averaged over a long period, we can treat it as constant.

Now let's move onto the elementary operations of insert, delete, and modify. The fact that there can be no uninitialized elements in our list means that there are extra nuances.

**Algorithm 1.0 (Retrieve  $i$ th Element from List)**

Retrieval of element  $L[i]$  at index  $i$  is  $O(1)$ .

**Algorithm 1.0 (Add Element to  $i$ th Index in List)**

Adding is a bit different. There are two cases.

1. *Adding to fixed index away from end.* If we do not have to grow the list, then we simply initialize the first open position with space this is  $O(1)$ . If we have to grow the list, this is  $O(n)$ .
2. *Adding to any other index  $i$ .* If we have to grow the list, then we can add the elements  $\hat{L}[j] \leftarrow L[j]$  for  $j < i$ , then  $\hat{L}[i] = b$ , and then  $\hat{L}[j + 1] = L[j]$  for  $j > i$ .

Now assuming that we are using a geometric growth scheme (of 1, 2, 4, ...), as we start with a list of size 0 (array size 1) and add  $n$  elements to it, the total values copied is

$$1 + 2 + 4 + \dots + (N/4) + (N/2) = N - 1 \quad (26)$$

Therefore, even though each growth is linear time, the frequency decays exponentially to the point that this is  $O(n)$ . Therefore, adding to the end of a list is *on average*  $O(1)$  time, also called *amortized constant time*.

**Algorithm 1.0 (Modify  $i$ th Element in List)**

To modify  $L[i]$  to a new value  $b$  in a list, we can do this to the underlying array  $A[i] \leftarrow b$  in  $O(1)$  time.

**Algorithm 1.0 (Contains in a List)**

Contains behaves the same as an array, with  $O(n)$  time.

**Algorithm 1.0 (Delete  $i$ th Element from List)**

Deleting also changes similarly to adding.

1. *Deleting to fixed index away from end.* We can delete it from the underlying array in  $O(1)$  time, but this leaves  $A[i] = \emptyset$ . We must shift the rest of the rightmost elements to the left:  $A[j] \leftarrow A[j + 1]$  for  $i \leq j \leq n - 1$ . But since  $j$  is a fixed index away from the end, we only have to most at most a constant number of elements  $j$ , so this is  $O(j) = O(1)$ .
2. *Deleting to any other index  $i$ .* We have the same logic, but since  $j$  is now not constant and can be any other index. Therefore in the worst case  $j = 0$ , and we must shift the entire array, leading

to  $O(n)$  runtime.

3. *Deleting Index with Certain Value.* If we want to delete a certain value, we want to first scan the array to see if there contains an element with this value, and if so, we delete it. This gives  $O(n)$  time.

### Example 1.2 (String)

The string type is just an ArrayList of characters. It has the following attributes and methods. Let `x = "I love CS201"`

1. `int y = x.length()` outputs the length and is  $O(1)$
2. `char y = x.charAt(0)` outputs a character and is  $O(1)$
3. `String y = x.substring(0, 4)`
4. `boolean y = x.equals("I love CS201")`
5. `String y = x + "!!"`
6. `String[] y = x.split(" ")`
7. `String y = String.join(" ", words)`

While we could technically concatenate or reverse arrays, the presence of uninitialized elements make the algorithms implementation specific. We focus on lists.

### Algorithm 1.0 (Concatenating two Lists)

### Algorithm 1.0 (Reversing List)

$O(n)$

## 1.2 Linked List and Iterators

### Definition 1.3 (Singly Linked List)

A **singly linked list** contains a sequence of nodes that each contain an object for its element and a reference to the next node. More specifically, it can be divided up into 3 parts:

1. The variable which points to the *first* node. This can be confusing since this variable, which represents an *entire list* is just a pointer to the first node.
2. A sequence of nodes containing the element and a reference to the next node.
3. The final node containing the element and a reference to `null`.

Unlike a list however, we will use **one-indexing** for linked lists, i.e. the head node is located at index 1.

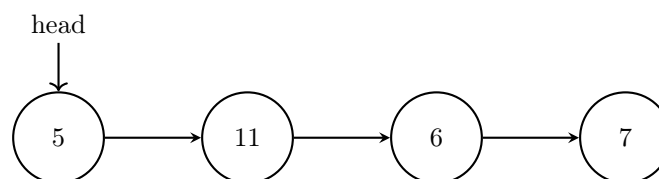

Figure 2: The following diagram represents a linked list. But in reality, the elements are all located random in memory and can only be found by references.

**Algorithm 1.0 (Retrieve  $i$ th Element from Linked List)**

Given a linked list of size  $n$  and some  $1 \leq i \leq n$ , retrieval of the  $i$ th value is  $O(i)$ , which

1. in best case is  $O(1)$  if  $i$  is a fixed number not dependent on  $n$ .
2. in worst case is  $O(n)$  if  $i = n$ , since we have to traverse through the  $n - 1$  nodes.

This is the first time we actually look at a nontrivial algorithm.

**Algorithm 1.0 (Insert Element to  $i$ th Index in Linked List)**

To add value  $b$  as the  $i$ th element of a linked list, we must have first traverse through to the  $i - 1$  node  $a_{i-1}$ , then set it to point to  $b$ , and finally have  $b$  point to  $a_i$ . The runtime is dominated by the first step of traversing, which is  $O(i)$  and may be

1.  $\Theta(1)$  in the best case when  $i = 1$ , or
2.  $\Theta(n)$  in the worst case when  $i = n$

Note that this allows us to easily add to the beginning of a linked list, which was inefficient for regular lists. However, we now sacrifice the easy cost of adding to the end of the list, which worsened from  $\Theta(1)$  to  $\Theta(n)$ .

```

1: procedure ADDELEMENTTOLINKEDLIST
2:   Linked list  $L$ , value  $b$ , index  $i$  to insert to
3:    $h, c \leftarrow L$  ▷create references to head and current
4:   for  $i \leftarrow 1 \dots i - 2$  do
5:      $c \leftarrow c.next$ 
6:   end for
7:    $t \leftarrow c.next$  ▷Store temporary reference to  $a_i$ 
8:    $c.next \leftarrow b$  ▷ $a_i$  points to  $b$ 
9:    $b.next \leftarrow t$  ▷ $b$  points to  $a_{i+1}$ 
10:  return  $h$  ▷return head
11: end procedure

```

**Algorithm 1.0 (Modify  $i$ th Element in Linked List)**

Modifying is trivial since you just traversing the linked list to the  $i$ th node and then replace the value there.

1. If  $i$  is constant, then this is  $\Theta(1)$ .
2. If  $i = n$  in the worst case, then this is  $\Theta(n)$ .

**Algorithm 1.0 (Contains in a Linked List)**

Checking containment just requires us to loop through all nodes and then determine whether our input value is equal to the value stored in the node. This requires us to loop through the entire list so is  $\Theta(n)$ .

**Algorithm 1.0 (Delete  $i$ th Element from Linked List)**

Deleting  $a_i$  is the same logic as adding. We traverse the linked list until we get to node  $a_{i-1}$ , and then we set it to point to  $a_{i+1}$ . The runtime is dominated by the first step of traversing, which is  $O(i)$  and may be

1.  $\Theta(1)$  in the best case when  $i = 1$ , or
2.  $\Theta(n)$  in the worst case when  $i = n$

```

1: procedure DELETEELEMENTFROMLINKEDLIST
2:   Linked list  $L$ , index  $i$  to insert to
3:    $h, c \leftarrow L$  ▷create references to head and current
4:   for  $i \leftarrow 1 \dots i - 2$  do
5:      $c \leftarrow c.next$ 
6:   end for
7:    $c.next \leftarrow c.next.next$  ▷Skip the next node and have it point to the node after
8:   return  $h$  ▷return head
9: end procedure

```

### Algorithm 1.0 (Concatenating 2 Linked Lists)

Given two linked lists  $L_1, L_2$  of size  $n, m$ , concatenating them to list  $L_1 \oplus L_2$  is  $O(n + m)$ .

```

1: procedure CONCATENATELINKEDLISTS
2:   Linked lists  $L_1, L_2$ 
3:    $h_1, c_1 \leftarrow L_1$  ▷create references to head and current of  $L_1$ 
4:   if  $h_1 = \text{null}$  then ▷if  $L_1$  is empty
5:     return  $L_2$  ▷return  $L_2$  as the result
6:   end if
7:   while  $c_1.next \neq \text{null}$  do ▷traverse to the end of  $L_1$ 
8:      $c_1 \leftarrow c_1.next$ 
9:   end while
10:   $c_1.next \leftarrow L_2$  ▷link the last node of  $L_1$  to the head of  $L_2$ 
11:  return  $h_1$  ▷return the head of the concatenated list
12: end procedure

```

### Algorithm 1.0 (Reversing a Linked List)

Given a linked list  $L$  of size  $n$ , reversing it has time complexity  $O(n)$  as we need to traverse the entire list once. There is both an iterative and recursive approach.

```

1: procedure ITERATIVEREVERSELINKEDLIST
2:   Linked list  $L$ 
3:    $prev \leftarrow \text{null}$  ▷previous node, initially null
4:    $curr \leftarrow L$  ▷current node, starts at head
5:    $next \leftarrow \text{null}$  ▷to temporarily store the next node
6:   while  $curr \neq \text{null}$  do
7:      $next \leftarrow curr.next$  ▷store next node
8:      $curr.next \leftarrow prev$  ▷reverse the pointer
9:      $prev \leftarrow curr$  ▷move prev forward
10:     $curr \leftarrow next$  ▷move curr forward
11:  end while
12:  return  $prev$  ▷prev is the new head of reversed list
13: end procedure

1: procedure RECURSIVEREVERSELINKEDLIST( $head$ )
2:   if  $head = \text{null}$  or  $head.next = \text{null}$  then
3:     return  $head$  ▷Base case: empty list or single node
4:   end if
5:    $newHead \leftarrow \text{RECURSIVEREVERSELINKEDLIST}(head.next)$  ▷Reverse the rest
6:    $head.next.next \leftarrow head$  ▷Make next node point to current
7:    $head.next \leftarrow \text{null}$  ▷Remove original next pointer

```

```

8:   return newHead
9: end procedure

```

▷Return the new head (original tail)

#### Definition 1.4 (Doubly Linked List)

A **doubly linked list** contains a sequence of nodes where each node contains an object for its element, a reference to the next node, and a reference to the previous node.

1. The variable which points to the 1st node is called the **head**. As with singly linked lists, this variable represents the *entire list* but is just a pointer to the first node.
2. A sequence of nodes, each containing the element, a reference to the next node, and a reference to the previous node.
3. The final **tail** node containing the element, a reference to **null** for its next pointer, and a reference to the second-to-last node for its previous pointer.

Similar to singly linked lists, we will use **one-indexing** for doubly linked lists, i.e., the head node is located at index 1.

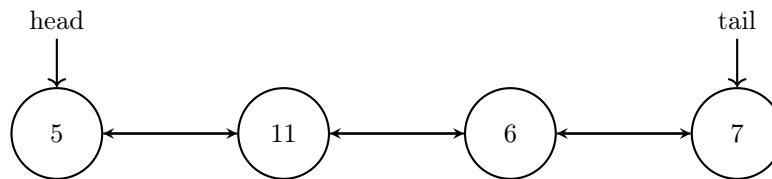

Figure 3: This diagram represents a doubly linked list. Forward pointers are shown in black, while backward pointers are shown in red. As with singly linked lists, the elements are located randomly in memory and can only be found through references. The presence of backward pointers allows for bidirectional traversal.

While we have to keep an extra pointer for every node in memory, this allows for simpler and sometimes more efficient implementations of the algorithms. For example, reversing a linked list can be done by simply swapping the previous and next pointers in each node. We can also add to and remove from both the front and back of a linked list in  $O(1)$  time.

#### Definition 1.5 (Circular Linked List)

A **circular linked list** is a variation of a linked list where the last node, instead of pointing to null, contains a reference back to the first node, forming a circle or loop. This structure can be applied to both singly and doubly linked lists:

1. In a circular singly linked list, the last node's next pointer references the head node.
2. In a circular doubly linked list, the last node's next pointer references the head node, and the head node's previous pointer references the last node.

This circular nature allows traversal of the entire list starting from any node, as following the next pointers will eventually cycle through all nodes.

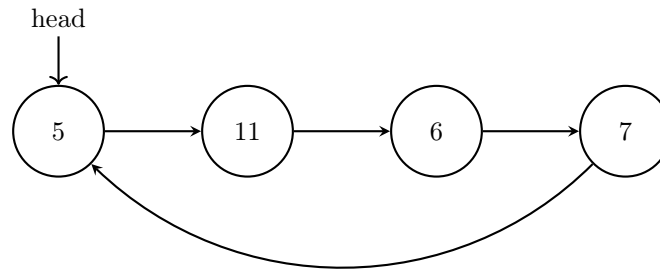

Figure 4: A circular singly linked list where the last node points back to the head node, creating a cycle. This structure eliminates the concept of a “null end” found in standard linked lists.

Let’s introduce one more data structure. Note that even though our basic linked list solves the problem of adding in the beginning, in order to add in the middle or end, we must get to that position (which is  $O(n)$  time) before we are able to utilize our  $O(1)$  add. This is quite inefficient, especially when we do repeated adding, so we should keep track of certain “markers” that indicate where our current node is. *Iterators* do this naturally, so we would like to implement some current notion of position.

#### Definition 1.6 (Iterator)

An **iterator** is a structure that maintains a reference a *current position* within a list, along with methods to move the iterator to the next node (and previous node in doubly linked lists).

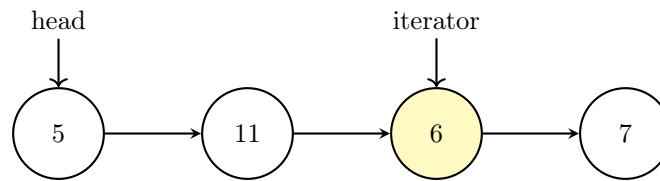

Figure 5: A linked list with an iterator currently positioned at the node containing the value 6. The iterator allows for immediate access to this position without traversing from the head.

At first glance it may seem like iterators are just lists with less functionality, but we will see later that even non-array-like data structures can be turned into lists.

### 1.3 Stacks

A stack is pretty much a list with a more limited set of operations, so whatever we can do with a stack we can do with a list. However, it is worth mentioning as its own data structure since it allows us to work with a simpler interface.

#### Definition 1.7 (Stack)

A **stack** is a data structure that stores data in the *last-in-first-out (LIFO)* paradigm, which means that we can push (insert) elements into a stack  $S$  and pop (remove) the last element that was pushed.

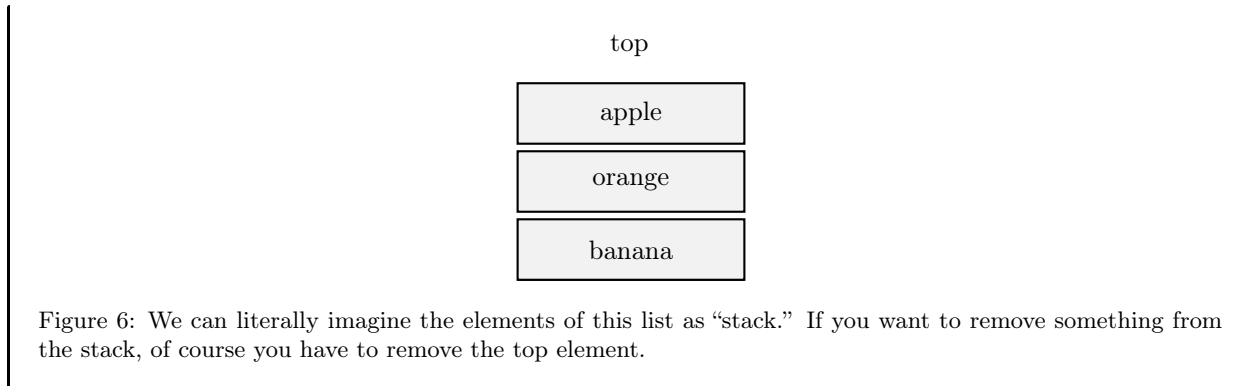

The actual implementation can be done in many ways, either through a list or a linked list.

#### Algorithm 1.0 (Push onto Stack)

To push, i.e. add an element, onto the stack, we can

1. insert to the end of a list, which is amortized  $\Theta(1)$ .
2. insert to the head of a singly linked list, which is  $\Theta(1)$ .

#### Algorithm 1.0 (Pop from Stack)

To pop, i.e. remove the last element pushed, from the (top of the) stack, we can

1. remove the last element of a list, which is  $\Theta(1)$ .
2. move the head pointer to the second node and return the first node, which is  $\Theta(1)$ .

#### Algorithm 1.0 (Peek into Stack)

To peek, i.e. retrieve only the value at the top of the stack, we can

1. return the last element of a list, which is  $\Theta(1)$ .
2. return the value of the head of the linked list, which is  $\Theta(1)$ .

## 1.4 Queues

#### Definition 1.8 (Queue)

A **queue** is an data structure that stores elements in the *first-in-first-out (FIFO)* paradigm, which means that we can enqueue (insert) elements into a queue  $Q$  and *dequeue* (remove) elements in the order that they were pushed.

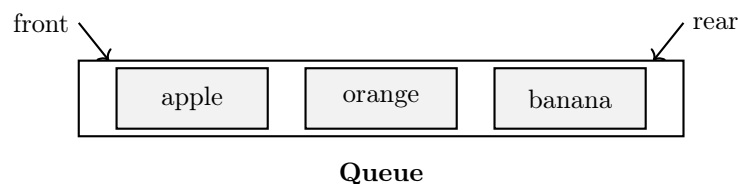

Figure 7: This is just like how a queue works. Whatever has been waiting in the queue the longest is the one that is removed first (at the front).

Unlike a stack, which can be implemented with a list or linked list, for queues we must implement with a

linked list with both a head and a tail pointer (or a doubly linked list). If we use a list, then to enqueue in  $\Theta(1)$  time we must have it add to the end of the list, but when dequeuing, we must remove from the front of a list, which is inevitably  $\Theta(n)$ . The linked list has the opposite problem. Dequeuing is easy since we can shift the head node, but enqueueing requires us to traverse to the end before adding another node, which is  $\Theta(n)$ . In fact, Python implements this as a double ended queue.<sup>2</sup> However, we will work with the minimal data structure of a singly linked list with a head and tail pointer.

**Algorithm 1.0 (Enqueue onto Queue)**

To enqueue an element  $b$ , we can have the tail pointer  $a_n$  point to  $b$  and update the tail pointer to  $b$ . This is  $\Theta(1)$ .

**Algorithm 1.0 (Dequeue onto Queue)**

To dequeue, we can return the head  $a_1$  and update the head pointer to  $a_2$ .

**Algorithm 1.0 (Peek into Queue)**

To peek into the queue, we can simply return the value of the head pointer  $a_1$ .

---

<sup>2</sup>`from collections import deque` where deque stands for double ended queue.

## 2 Hash-Based Data Structures

### 2.1 Hashing

One of the most important applications of hashing and probabilistic algorithms is in cryptography. For example, when you generate a RSA keypair, you must choose two 128-bit prime numbers which serve as your private key. State of the art methods simply generate a random 128-bit prime number perform *independent* randomized probabilistic tests with error rate  $\epsilon$ . Given that this is independent, simply running this tests  $k$  times reduces our error exponentially to  $\epsilon^k$ , practically guaranteeing primality. In Bitcoin and Ethereum wallets, hardened child key derivation functions in hierarchical deterministic wallets hash subsets of the parent key to generate both the child keys and their seeds.<sup>3</sup>

Assume we want to map keys from some **universe**  $U$  into a smaller set  $[N] = \{1, \dots, N\}$  of  $N$  bins. The algorithm will have to handle some dataset  $S \subset U$  of  $|S| = M$  keys.<sup>4</sup> We want to store  $S$  with efficient performance in

1. `Find(x)`, which returns true if  $x \in S$
2. `Insert(x)`
3. `Delete(x)`

This is essentially a set. If one is new to hashing, we could try to use a balanced binary search tree or a heap (implemented as a red-black tree or some other variant), which can do all three operations in  $O(\log(N))$  time. If we had access to a randomized function  $h : U \rightarrow [N]$ , with the property that for a fixed  $x \in U$ ,  $h(x) \sim \text{Multinomial}(N)$ , then by linearity of expectation<sup>5</sup>

$$\mathbb{P}(h(x) = h(y)) = \mathbb{E}[\mathbb{1}_{h(x)=h(y)}] = \frac{N}{N^2} = \frac{1}{N} \quad (27)$$

This is great, but this is also random, which means that we are not guaranteed to map to the same bin across time. If we add time-invariance, this is pretty much a hash function, which is really deterministic, but we like to call it psuedo-random.

So what if there are collisions? They are inevitable anyways even with a completely random function, but minimizing them will give us the best runtime performance. There are a two main ways to approach this.

1. At each bin, store the head of a linked list, BST, or another hash table. You would incur an additional linear, logarithmic, or constant cost of traversing this data structure for each operation.
2. Look for another bin. We can just look at  $h(x) + 1$  or  $h(h(x))$  (or really any deterministic function  $f(h(x))$ ) if  $h(x)$  is occupied.

This is what we have to work with here, so we would like to modify our assumptions. Therefore, we can achieve good performance by reducing the collisions and by improving how we deal with collisions. We will focus on the first part, and we would like for our hash functions to have some nice properties, which we will define. The most intuitive way is to treat  $x, y$  as random variables uniformly sampled from  $U$ , and then we would like  $\mathbb{P}(h(x) = H(y)) \approx 1/N$ . However in practice, this is not the case since our subdomain  $S$  is already fixed, yet may be unknown. Therefore given any function  $h$ , we can construct an adversarial sequences of inputs that will all map to the same bin. We must therefore consider a *family* of hash functions.

#### Definition 2.1 (Universal Hashing)

A family of hash functions  $H = \{h : U \rightarrow [N]\}$  is **universal** if for any fixed  $x, y \in U$ ,

$$\mathbb{P}_h(h(x) = h(y)) \leq \frac{1}{N} \quad (28)$$

<sup>3</sup>For an implementation of both, look at my blockchain implementation here

<sup>4</sup>For example, think of all possible strings as  $U$  and all 256-bit numbers as  $N = 2^{256}$ .  $S$  in this case  $S$  may be the set of all addresses on a blockchain. This is SHA256, and to date there is no known hash collisions, though there are a few for SHA1.

<sup>5</sup>Note that this is not  $\mathbb{P}_{x,y}$  since  $x, y$  are not random variables. They are fixed, and  $h(x), h(y)$  are the random variables.

where  $h$  is drawn uniformly. If the bound is  $2/N$  then it is called **near-universal**, and what's important is the  $N$  in the denominator. This polynomial decay in collision probabilities is exactly what we need for constant operation time. That is, given query  $x$ , let the random variable  $X$  be the number of operations we must do to find  $X$ , which consists of 1 pointer traversal plus some other amount of traversals (e.g. through a linked list) if collision, say which is  $C_n$ . So we have

$$X = 1 + \sum_{y \in S} Q_y \quad (29)$$

where 1 comes from the initial pointer traversal in hashing, and Bernoulli  $Q_y = 1$  if  $h(y) = h(x)$ .<sup>a</sup> Then, by linearity of expectation combined with the bound on probability of collision we have

$$\mathbb{E}[X] = 1 + \sum_{y \in S} \mathbb{E}[Q_y] = 1 + |S| \cdot \mathbb{P}(h(x) = h(y)) = 1 + \frac{|S|}{N} \quad (30)$$

which is constant.

<sup>a</sup>This may not be 1 since we may have to do more than 1 additional traversal, e.g. in linked lists. But we assume the extra cost is bounded by a constant.

If  $H$  is the set of all functions from  $U$  to  $[N]$ , then this universal property is trivially satisfied since

$$\mathbb{P}_h(h(x) = h(y)) = \frac{1}{N} \quad (31)$$

But this is quite a complex function class and  $h$  may not be easy to store, i.e. may not be analytic. The question now becomes whether we can achieve universality with a smaller class. It turns out yes, and the obvious use is to use cyclic groups.

### Lemma 2.1 (Carter-Wegman 71)

Suppose  $U = \{0, 1, \dots, M-1\}$ . We choose a prime  $p \geq M^a$  and construct the family

$$H = \{h_a(x) = (ax \bmod p) \bmod N \mid a = 0, \dots, p-1\} \quad (32)$$

We claim this is near-universal.

<sup>a</sup>It is guaranteed that a prime exists between  $m$  and  $2m$ .

*Proof.* We treat  $x$  as the generator of this group, and then  $ax \bmod p = a'x \bmod p$  iff  $a = a'$ . Therefore,

$$\mathbb{P}_a(h_a(x) = h_a(y)) = \mathbb{P}_a((ax - ay) \bmod p = Nk) \quad (33)$$

for some  $k$ . If  $a = 0$ , then everything collides, but if  $a \neq 0$  and  $x \neq y$ , then  $ax - ay$  must have a difference of exactly a multiply of  $N$ , which happens with probability  $1/N$ . Therefore, we have

$$\mathbb{P}_a(h_a(x) = h_a(y)) = \mathbb{P}(a = 0) + \mathbb{P}(a \neq 0) \cdot \frac{1}{N} = \frac{1}{p} + \frac{p-1}{p} \cdot \frac{1}{N} < \frac{2}{N} \quad (34)$$

since  $p > N$ .

Therefore, to hash,

1. we choose a prime  $p \geq m = |U|$ .
2. choose  $a \in \{0, 1, \dots, p-1\}$  at random.

3. Use  $h_a(x) = (ax \bmod p) \bmod N$  to hash everything.<sup>6</sup>

### Example 2.1

Let  $n$  be a fixed prime number and

$$H = \{h_{a,b}(x, y) = ax + by \bmod n : a, b \in [n]\} \quad (35)$$

We claim that this is universal. Let  $x = (x_1, x_2)$  and  $y = (y_1, y_2)$  be arbitrary pairs of integers where  $x \neq y$ . WLOG, assume  $x_2 \neq y_2$ . Then

$$\mathbb{P}(h_{a,b}(x) = h_{a,b}(y)) = \mathbb{P}(ax_1 + bx_2 = ay_1 + by_2) = \mathbb{P}(a(x_1 - y_1) = b(y_2 - x_2)) \quad (36)$$

Suppose that we pick  $a$  first and we compute the conditional probability. Then the LHS is a constant, and for this to hold in a cyclic group,  $b$  must equal  $c(y_2 - x_2)^{-1}$ , which occurs with probability  $1/N$ . Using LOTP the joint probability is also  $1/N$ .

## 2.2 Set

Sets are conceptually the same as mathematical sets.

### Definition 2.2 (Set)

A **set** is an unordered data structure that stores unique elements.

1. Add is  $O(1)$ .
2. Remove is  $O(1)$ .
3. Retrieval and contains is  $O(1)$ .

## 2.3 Map

A hash table is an array of key value pairs. But rather than adding to positions in order from 0, 1, 2, ..., we will calculate the hash of the key, which would return an int that specifies where we store this key-value pair. So to store,  $\langle \text{"ok"}, 8 \rangle$ , we will calculate  $\text{hash}(\text{"ok"}) == 5$  and store it in the 5th index.

```

1 0
2 1
3 2 <"hi", 5>
4 3
5 4
6 5 <"ok", 8>
7 6
8 7

```

We can immediately see how this makes search easier, since if we want to find the value associated with the key "ok", then we can calculate the hash of it to find the index and look it up on the array.

### Definition 2.3 (Maps)

A **map**, also called a **hash table**, is an unordered data data structure that stores key-value pairs.

1. Add is  $O(1)$ .
2. Remove is  $O(1)$ .
3. Retrieval and contains is  $O(1)$ .

<sup>6</sup>We do not change  $a$  every time we hash.

So running `get(key)` on a `HashMap` looks up position `hash(key)` in the hash table and returns the value there. Immediately, we see that if `hash` is not injective (which it isn't), then we can run into collisions. This is solved using chaining or bucketing. Bucketing basically takes each index in the array and stores not just one key-value pair, but a list of key-value pairs. So basically, when we want to search for the value of a key, we compute the index of it with `hash(key)`, which would return a list of key-value pairs.

Obviously, if we create a custom `hashCode()` method that trivially maps to 0, then we would just have one giant list in the bucket at index 0, which is no more efficient than a list search. So, we should ideally assume that given  $N$  pairs with  $M$  buckets, our hashing function is built so that the probability of two random (unequal keys) hash to the same bucket is  $1/M$ . Note that this hash function is completely deterministic. We should talk about runtime/memory tradeoff. Given  $N$  pairs and  $M$  buckets (with SUHA):

1.  $N \gg M$  means too many pairs in too few buckets, so runtime inefficient
2.  $M \gg N$  means too many buckets for too few pairs, so memory wasteful
3.  $M$  slightly larger than  $N$  is the sweet spot.

To maintain an ideal ratio, we basically create a new larger table (with geometric resizing) and rehash/copy everything until we reach it.

### 3 Graph-Based Data Structures

So far, arrays and hashing are the two most intuitive ways that we would store data. The next set of data structures not only store values, but it store the *interactions* between these values. While it may not seem as natural to the new-comer, trees—and more generally, graphs—are a natural way to store real-world data.

At this point, you should be familiar with the concept of *recursive algorithms*, which naturally appears in graphs (e.g. a subtree of a tree is a tree itself). Unlike the previous data structures, the elementary operations on graphs (e.g. insert, remove, etc.) are not as trivial, and so the conceptual difficulty significantly jumps from here.

#### 3.1 Graphs

##### Definition 3.1 (Undirected Graphs)

An **undirected graph**  $G(V, E)$  is a tuple, where  $V = \{v_1, \dots, v_n\}$  is the vertex set and  $E = \{\{v_i, v_j\}\}$  is the edge set.

1. The **degree**  $d_v$  of a vertex  $v$  is the number of edges incident to it.
2. A **path** is a sequence of vertices where adjacent vertices are connected by a path in  $E$ . Its **length** is the number of edges in the path.
3. A **cycle/circuit** is a path that has the same start and end.
4. A graph is **connected** if for every pair of vertices  $e_i, e_j \in E$ , there is a path from  $e_i$  to  $e_j$ .
5. A **connected component** is a maximal subset of connected vertices.

The **size** of a graph is a tuple  $(n, m) = (|V|, |E|)$ .

##### Definition 3.2 (Directed Graph)

A **directed graph**  $G(V, E)$  is a tuple, where  $V = \{v_1, \dots, v_n\}$  is the vertex set and  $E = \{(v_i, v_j)\}$  is the edge set (note that it is a set of tuples, so  $(i, j) \neq (j, i)$ ).

1. The **in/out degree**  $d_{v,i}, d_{v,o}$  of a vertex  $v$  is the number of edges going in to or out from  $v$ .
2. A **path** is a sequence of vertices where adjacent vertices are connected by a path in  $E$ . Its **length** is the number of edges in the path.
3. A **cycle/circuit** is a path that has the same start and end.
4. A directed graph is **strongly connected** if for every pair of vertices  $e_i, e_j \in E$ , there is a path from  $e_i$  to  $e_j$ .<sup>a</sup>
5. A **strongly connected component** is a maximal subset of connected vertices.

<sup>a</sup>Obviously, a connected undirected graph is also strongly connected.

In fact, from these definitions alone, we can solve an ancient puzzle called *the Bridges of Königsberg*. Euler, in trying to solve this problem, had invented graph theory.

##### Example 3.1 (Bridges of Königsberg)

Is there a way to walk that crosses each bridge *exactly* once?

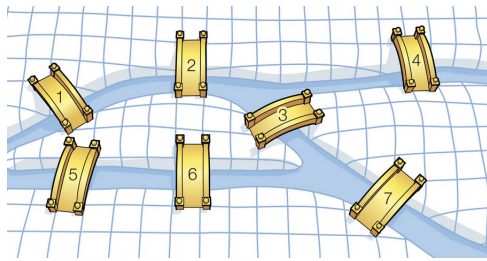

(a) Figure of the bridges of Königsberg.

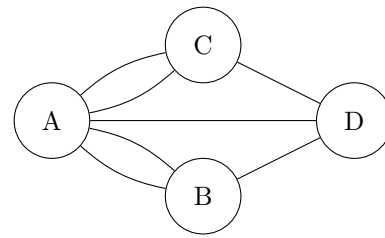

(b) Graph representation.

Figure 8: It can be decomposed into this undirected graph.

Euler's observation is that except for start and end points, a walk leaves any vertex by different edge than the incoming edge. Therefore, the degree (number of edges incident on it) must have an even number, so all but 2 vertices must have an even degree. Since every vertex has an odd degree, there is no way of doing it.

In addition to the *adjacency list* representation, another way in which we represent a directed graph is through *adjacency matrices*.

### Definition 3.3 (Adjacency Matrix)

In a finite directed graph  $(V, E)$ , we can construct a bijection from  $V$  to the natural numbers and so we label each element in  $V$  with  $i \in \mathbb{N}$ . Then, we can construct a matrix  $A$  such that

$$A_{ij} = \begin{cases} 1 & \text{if } (i, j) \in E \\ 0 & \text{if } (i, j) \notin E \end{cases} \quad (37)$$

### Example 3.2 (Adjacency List vs Matrix)

Given a graph, we can completely represent it with a list of adjacent vertices for each vertex or an adjacency matrix.

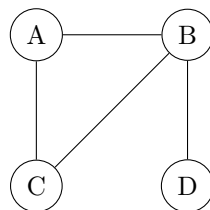

An adjacency list would look something like this

$A : B, C$   
 $B : A, C, D$   
 $C : A, B$   
 $D : B$

and the adjacency matrix looks like this:

	<i>A</i>	<i>B</i>	<i>C</i>	<i>D</i>
<i>A</i>	0	1	1	0
<i>B</i>	1	0	1	1
<i>C</i>	1	1	0	0
<i>D</i>	0	1	0	0

While the adjacency matrix does have its advantages and has a cleaner form, usually in sparse graphs this is memory inefficient due to there being an overwhelming number of 0s.

**Algorithm 3.0 (Insert Node/Edge in Graph)****Algorithm 3.0 (Remove Node/Edge in Graph)****Algorithm 3.0 (Contains in Graph)**

### 3.2 Graph Traversal with DFS/BFS

Given two  $v, s \in V$  either directed or undirected, how can we find a path from  $v$  to  $s$ ? We can do with either with DFS or BFS.

Now, in order to traverse this graph, we basically want to make an algorithm that starts at a node, prints its value, and then goes to all of its neighbors (which we can access through the adjacency list) to print them out. Thus, this is by nature recursive. We don't want the algorithm to loop around printing nodes infinitely often, so we must create a base case that tells the algorithm to not print out a node. It makes sense to create a set of visited nodes, which we can add to whenever we reach a new node. So, if we ever come onto a node that we have visited, we can just tell the function to do nothing.

**Algorithm 3.0 (Recursive Depth-First Search)**

The recursive implementation of Depth-First Search explores a graph by recursively visiting each unvisited neighbor, going as deep as possible along each branch before backtracking.

---



---

**Require:** Graph  $G(V, E)$ , start vertex  $s$

```

1: function DFS-RECURSIVE( $G, s$ )
2:   visited  $\leftarrow \emptyset$  ▷Initialize empty set of visited vertices
3:   DFS-VISIT( $G, s$ , visited)
4: end function
5: function DFS-VISIT( $G, u$ , visited)
6:   Add  $u$  to visited
7:   /* Process vertex  $u$  here */
8:   for each neighbor  $v$  of  $u$  in  $G$  do
9:     if  $v \notin$  visited then
10:       DFS-VISIT( $G, v$ , visited)
11:     end if
12:   end for
13: end function

```

---

Though recursion really makes this simple, we can construct an iterative approach that uses stacks. Note that in recursion, we are really making a call stack of different functions. We can be explicit about this by actually implementing a stack, which would store all the nodes that we have discovered, but not yet explored from (i.e. all the current nodes). At each iteration, we would pick a node to continue exploring, and since this is a DFS, we would want to implement a LIFO stack so that the last element we input in is the first thing that we should explore from, i.e. we always explore from the last node discovered.

### Algorithm 3.0 (Iterative Depth-First Search)

The iterative implementation of Depth-First Search uses a stack to mimic the function call stack of the recursive implementation. It explores vertices in the same order as the recursive version.

---



---

**Require:** Graph  $G(V, E)$ , start vertex  $s$

```

1: function DFS-ITERATIVE( $G, s$ )
2:   visited  $\leftarrow \emptyset$  ▷Initialize empty set of visited vertices
3:   stack  $\leftarrow$  empty stack
4:   Push  $s$  onto stack
5:   Add  $s$  to visited
6:   while stack is not empty do
7:      $u \leftarrow$  Pop from stack
8:     /* Process vertex  $u$  here */
9:     for each neighbor  $v$  of  $u$  in  $G$  do
10:      if  $v \notin$  visited then
11:        Add  $v$  to visited
12:        Push  $v$  onto stack
13:      end if
14:    end for
15:  end while
16: end function

```

---

### Example 3.3 (DFS Walkthrough)

Let's conduct DFS on the following graph.

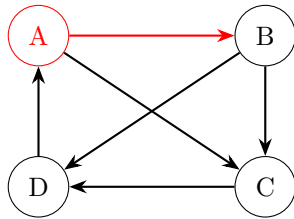

(a) You start at  $A$  and you add it to your visited set  $V = \{A\}$ . You look at your neighbors and find that you can explore  $B$  or  $C$ . Let's randomly choose to explore  $B$  but keep in mind that you haven't finished exploring from  $B$  since there's  $C$  left.

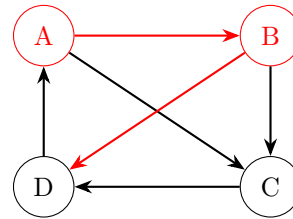

(b) You add  $B$  to visited  $V = \{A, B\}$  and look at your neighbors  $C$  and  $D$ . Let's just choose  $D$  randomly but keep in mind that you have  $C$  to explore later, so you haven't finished exploring from  $B$  either. Therefore both  $A$  and  $B$  are both still on your exploration stack.

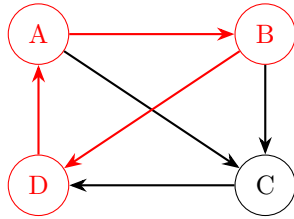

(c) You add  $D$  to visited  $V = \{A, B, D\}$ . You look at your neighbors and see that you can explore  $A$ . However it is already in your visited set. Since there are no more neighbors to explore to, you are done exploring from  $D$  and don't need to look at it anymore.

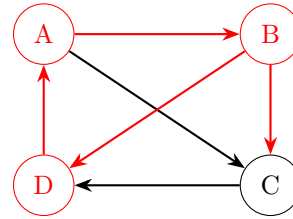

(d) Therefore you look back to where you came from:  $B$ , and continue exploring from  $B$ . You go back to  $B$  and look at the other nodes you must explore. You've already done  $D$  and the only remaining is  $C$ , which isn't in your visited.

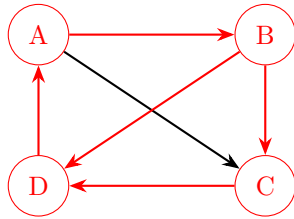

(e) Add  $C$  to visited  $V = \{A, B, C, D\}$ . You look at your neighbors and see  $D$  as the only neighbor to explore. However, you have already explored  $D$  and so there are no more neighbors left. Therefore you go back to the node you came from:  $B$ .

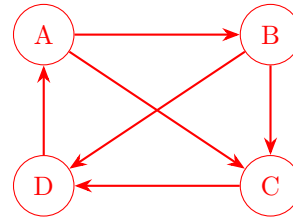

(f) You continue exploring from  $B$ . There are no more nodes to explore, so you go back to the node you came from  $A$ . You see that the only remaining neighbor to explore is  $C$ , but it is already in visited, so you don't need to explore it. You are done.

Figure 9: Walkthrough of DFS on a small graph. The iterative and recursive approaches are identical.

### Theorem 3.1 (Runtime of DFS)

The runtime of DFS is  $O(n + m)$ .

*Proof.* The runtime complexity of this search is  $O(N + M)$  because first, the while loop loops at most over the  $N$  nodes. The for loop may loop over  $M$  edges, but this is a bit pessimistic in bound. Rather, we can view it as looping over neighbors of each node at most exactly once, and so it considers every edge twice, meaning that the for loop will get called  $2M$  times in the entire algorithm. So  $N + 2M = O(N + M)$ .

### Example 3.4 (DFS in a Maze)

We can represent a grid graph, like a maze, with a two dimensional array that stores whether it is connected north, east, south, and west, where boolean of true represents that there is a wall, and false

means there isn't a wall (so connected).

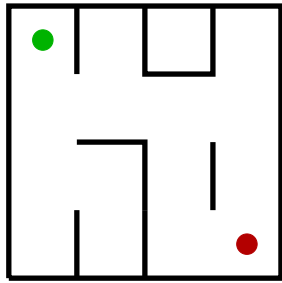

(a) 4×4 maze representation

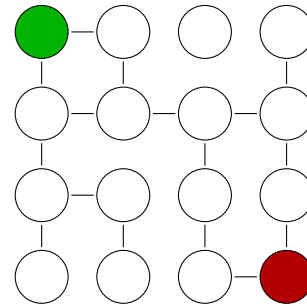

(b) Graph representation of the maze.

Figure 10: A 4×4 maze (left) and its corresponding graph representation (right). Start and end points are shown in green and red respectively.

But remember that in a tree traversal, we recursively searched down and down until we hit a null node, in which case we backtrack up to look in another branch. For graphs, this is a bit more complicated, since we could go in loops. Therefore, we want to keep track of all the visited nodes to avoid infinite recursion. We have three base cases:

1. If we search off the grid, then this is not a valid path
2. If we already explored here, then we don't want to repeat it
3. If we reached the goal of the maze, then we output the length of the path.

The recursive case would take each node and recurse on its 4 adjacent neighbors, if they are connected. Note that this algorithm recurses on each of the  $N$  nodes 4 times (for each direction, and each recursive call is  $O(1)$ ), so the complexity is  $O(N)$ .

Note that the main idea of DFS is to always explore a new adjacent vertex if possible, and if not, then backtrack to the most recent vertex adjacent to an unvisited vertex and continue. On the contrary, the main idea of BFS is to explore *all* your neighbors before you visit any of your neighbors' neighbors. It exhaustively searches for the closest regions of your search space before you look any further. Unlike DFS, which finds the some arbitrary path to a node, BFS finds the shortest (perhaps non-unique) path to a node. This can be simply done with a queue.

### Algorithm 3.0 (Iterative Breadth-First Search)

Breadth-First Search (BFS) explores a graph by visiting all neighbors at the current depth before moving to nodes at the next depth level. It uses a queue to process nodes in the order they are discovered.

**Require:** Graph  $G(V, E)$ , start vertex  $s$

```

1: function BFS( $G, s$ )
2:   visited  $\leftarrow \emptyset$                                 ▷Initialize empty set of visited vertices
3:   queue  $\leftarrow$  empty queue
4:   Enqueue  $s$  onto queue
5:   Add  $s$  to visited
6:   while queue is not empty do
7:      $u \leftarrow$  Dequeue from queue                      ▷Get the next vertex to process
8:     /* Process vertex  $u$  here */
9:     for each neighbor  $v$  of  $u$  in  $G$  do
10:      if  $v \notin$  visited then
11:        Add  $v$  to visited
12:        Enqueue  $v$  onto queue
13:      end if
14:    end for
15:  end while
16: end function

```

### Example 3.5 (BFS Walkthrough)

Let's conduct BFS on the following graph.

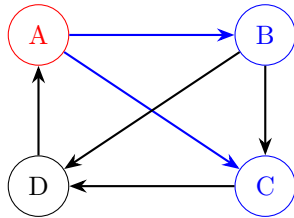

(a) You start at  $A$  and you add it to your visited set  $V = \{A\}$  and to your queue  $[A]$ . You immediately dequeue  $A$  from the queue and look at all neighbors of  $A$ , which are  $B$  and  $C$ . You add both to your queue in some random order, say  $B$  first.

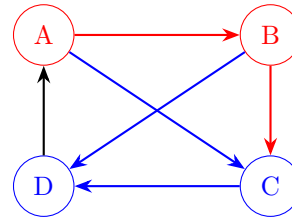

(b) You dequeue  $B$  and see that the adjacent nodes are  $C$  and  $D$ .  $C$  is already in your queue (check with visited set, which is  $O(1)$ ), so you do not put it into your queue and can mark the corresponding edges as explored. You do put  $D$  into the queue.

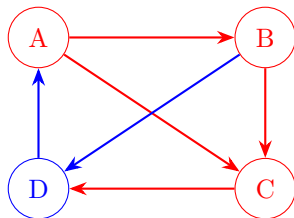

(c) Next you dequeue  $C$  since this is first seen from  $A$ . You explore from here and look at the neighbors, which is  $D$ . However,  $D$  is already in your queue from  $B$ , so you skip it. There are no more neighbors to explore from  $C$ , so we look at the queue again.

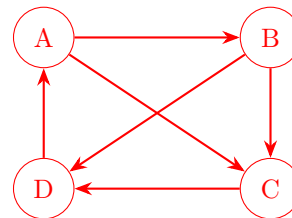

(d) You dequeue  $D$  and look at the neighbors. The only neighbor is  $A$  and it is already in visited, so we can skip this and mark the corresponding edge as explored. Since there are no more nodes to explore in our queue, this concludes BFS.

Figure 11: Walkthrough of BFS on a small graph. Blue represents the nodes/edges that are in our queue and red represents the nodes/edges that we have finished exploring.

**Theorem 3.2 (Runtime of BFS)**

The runtime of BFS is  $O(n + m)$ .

*Proof.* To get the running time, we know that each vertex is popped only once from the queue, giving us  $O(n)$ . For each pop, we are exploring all the neighbors of  $V$ .

$$O\left(\sum_{v \in V} |\text{neighbors of } v| + 1\right) = O\left(\sum_{v \in V} d_v + 1\right) \quad (38)$$

$$= O(2|E| + |V|) = O(m + n) \quad (39)$$

which is linear in input size!

The more straightforward application is in reachability.

**Example 3.6 (Reachability)**

Given a directed graph and a node  $v$ , find all nodes that are reachable from  $v$ .

**Definition 3.4 (Search Trees)**

Once we have traversed a graph using BFS or DFS, we can label the directed path that this traversal algorithm takes into a **search tree**.



(a) After DFS traversal, we can store the previous nodes in a hashmap  $\{B \mapsto A, D \mapsto A, E \mapsto D, F \mapsto E, C \mapsto F\}$ . From this we can see the path to get to  $C$  is  $A \mapsto D \mapsto E \mapsto F \mapsto C$  of length 4.

(b) After BFS traversal, we can store the previous nodes in a hashmap  $\{B \mapsto A, D \mapsto A, E \mapsto B, F \mapsto B, C \mapsto F\}$ . From this we can see the path to get to  $C$  is  $A \mapsto B \mapsto F \mapsto C$  of length 3.

Figure 12: Comparison of two directed graphs with different path lengths from  $A$  to  $C$ .

By construction, we can see that the path from  $A$  to  $C$  is always shorter for BFS than for DFS.

**3.3 Trees**

Now we look at one special type of graph, called a *tree*.

**Definition 3.5 (Tree)**

An undirected graph  $G(V, E)$  is a **tree** iff  $G$  is connected and has no cycles.<sup>a</sup>

1. The **root** of the tree is the top node.
2. The **leaf** of the tree are nodes that do not have children.
3. A **path** is any path from one node to another node. A simple path is a path that doesn't cross the same edge twice

4. The **height** of a node is the length of the longest downward path to a leaf from that node.
5. The **depth** of a node is the number of edges from the root to the node.
6. The **size** of the tree is the number of nodes  $n$  it contains.

<sup>a</sup>Removing the first requirement gives us the definition of a **forest**, which is a collection of trees.

### Theorem 3.3 (Properties of Trees)

If  $G(V, E)$  is a tree, then

1. There exists a  $v \in V$  s.t.  $d_v = 1$ , called a **leaf node**.
2.  $|E| = |V| - 1 = n - 1$ .

*Proof.* The outlines are quite intuitive.

1. There must be some leaf node since if there wasn't, then we would have a cycle. We can use proof by contradiction.
2. We can use proof by induction. We start off with one vertex and to construct a tree, we must add one edge and one vertex at every step, keeping this invariant.

Now we can get to the elementary operations on a tree.

### Algorithm 3.0 (Insert Node to Tree)

Inserting is a bit ambiguous since we most also know *where* to insert the value to. In general traversing this tree is  $O(\log n)$ , and so we have the same runtime.

```

1: procedure INSERT( $root, key, value$ )
2:   if  $root = \text{null}$  then
3:     return new Node( $key, value$ )
4:   end if
5:   if  $key < root.key$  then
6:      $root.left \leftarrow$  INSERT( $root.left, key, value$ )
7:   else if  $key > root.key$  then
8:      $root.right \leftarrow$  INSERT( $root.right, key, value$ )
9:   else
10:     $root.value \leftarrow value$  ▷Update if key already exists
11:  end if
12:  return  $root$ 
13: end procedure

```

### Algorithm 3.0 (Remove Node in Tree)

Removing is very similar, with also a runtime of  $O(\log n)$ .

```

1: procedure REMOVE( $root, key$ )
2:   if  $root = \text{null}$  then
3:     return null
4:   end if
5:   if  $key < root.key$  then
6:      $root.left \leftarrow$  REMOVE( $root.left, key$ )
7:   else if  $key > root.key$  then
8:      $root.right \leftarrow$  REMOVE( $root.right, key$ )
9:   else ▷Node with the key found

```

```

10:     if root.left = null then
11:         return root.right
12:     else if root.right = null then
13:         return root.left
14:     end if
15:     root.key ← FINDMIN(root.right)
16:     root.right ← REMOVE(root.right, root.key)
17: end if
18: return root
19: end procedure

```

### Algorithm 3.0 (Modify Node in Tree)

Same with modifying a node:  $O(\log n)$ .

```

1: procedure MODIFY(root, key, newValue)
2:   if root = null then
3:     return null
4:   end if
5:   if key < root.key then
6:     root.left ← MODIFY(root.left, key, newValue)
7:   else if key > root.key then
8:     root.right ← MODIFY(root.right, key, newValue)
9:   else
10:    root.value ← newValue
11:  end if
12:  return root
13: end procedure

```

▷Key not found

▷Update value when key is found

Since a node also has a specified depth and height, we should also know how to calculate this.

### Algorithm 3.0 (Height of Node)

The height of a node is the longest downward path to a leaf from that node, so its height would be the maximum of the two heights of its children. A null node would have height  $-1$ , which is our base case.

```

1: procedure GETHEIGHT(root)
2:   if root = null then
3:     return  $-1$ 
4:   end if
5:   return  $1 + \max(\text{GETHEIGHT}(\text{root.left}), \text{GETHEIGHT}(\text{root.right}))$ 
6: end procedure

```

### Algorithm 3.0 (Depth of Node)

The depth is quite hard to find recursively, but if we have a reference to the parent, then we can write

```

1: procedure DEPTH(node)
2:   if node = null then
3:     return  $-1$ 
4:   else
5:     return  $1 + \text{DEPTH}(\text{node.parent})$ 
6:   end if

```

```
7: end procedure
```

### 3.3.1 Binary Trees

Most of the time, we work with *binary trees*, which means that each node has at most 2 children, denoted a *left child* and *right child*.

#### Definition 3.6 (Binary Tree)

A **binary tree** is a recursive data structure in which every node has up to two children, which we call the **left child** and **right child**.

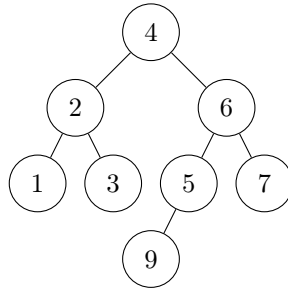

Figure 13: An example of a binary tree. The root is 4, with a max depth of 3.

A natural question is whether we can take this tree structure and retrieve all of its values. There are three recursive paradigms to do this, which differs by where the nonrecursive call is.

#### Algorithm 3.0 (In Order Traversal)

**In-Order traversal** tells us to print everything on the left of the node, then print the node, and then print everything on the right.

```

1: procedure INORDER(t)
2:   if t ≠ null then
3:     INORDER(t.left)
4:     print t.info
5:     INORDER(t.right)
6:   end if
7: end procedure

```

#### Algorithm 3.0 (PreOrder Traversal)

**Pre-Order traversal** tells us to print the node itself first, then print all the ones on the left, and then print all the ones on the right.

```

1: procedure PREORDER(t)
2:   if t ≠ null then
3:     print t.info
4:     PREORDER(t.left)
5:     PREORDER(t.right)
6:   end if
7: end procedure

```

**Algorithm 3.0 (PostOrder Traversal)**

**Post-Order traversal** tells us to print all the nodes on the left, then all ones on the right, and then the node itself.

```

1: procedure POSTORDER(t)
2:   if t ≠ null then
3:     POSTORDER(t.left)
4:     POSTORDER(t.right)
5:     print t.info
6:   end if
7: end procedure

```

**Example 3.7 (Converting Tree to List)**

It's worth to go over an example here. Given the following binary tree,

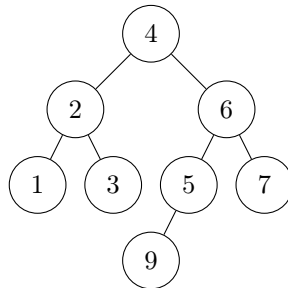

Figure 14: An example of a binary tree. The root is 4, with a max depth of 3.

If we initialize a list and replace the print statement with an insert to the (end of the) list, then

1. a in-order traversal produces: [1, 2, 3, 4, 9, 5, 6, 7]
2. a pre-order traversal produces: [4, 2, 1, 3, 6, 5, 9, 7]
3. a post-order traversal produces: [1, 3, 2, 9, 5, 7, 6, 4]

What we have described is a traversal method, and a natural question is to ask: Are these related to the more general DFS and BFS in any way? In fact it is.

**Theorem 3.4 (Tree Traversals and DFS)**

All forms of traversal are a specific variant of DFS starting from the root.

1. A pre-order traversal prioritizes the left node to explore and is the common DFS variant used in general graph traversal.
2. An in-order traversal always prioritizes adding an unexplored left child to the stack, and if there is no left child, then the node is printed, and then the right child is pushed to the stack and explored.
3. A post-order traversal always prioritizes adding an unexplored left child to the stack, and if there is no left child, then the right child is pushed to the stack and explored. Once the right child is finished exploring the parent node is printed.

So what does BFS do? There is another traversal which traverses the layers of each tree.

**Algorithm 3.0 (Level Order Traversal)**

**Level-order traversal** tells us to print all nodes of depth 0, then all nodes of depth 1, and so on.

```

1: procedure LEVELORDER( $t$ )
2:   if  $t \neq \text{null}$  then
3:     Create an empty queue  $Q$ 
4:     Enqueue  $t$  to  $Q$ 
5:     while  $Q$  is not empty do
6:        $node \leftarrow$  Dequeue from  $Q$ 
7:       print  $node.info$ 
8:       if  $node.left \neq \text{null}$  then
9:         Enqueue  $node.left$  to  $Q$ 
10:      end if
11:      if  $node.right \neq \text{null}$  then
12:        Enqueue  $node.right$  to  $Q$ 
13:      end if
14:    end while
15:  end if
16: end procedure

```

### 3.4 Heaps

A heap is sort of in between a sorted array and an unsorted array.

**Definition 3.7 (Binary Heap)**

A **binary heap** is a binary tree satisfying the following structural invariants:

1. Maintain the **heap property** that every node is less than or equal to its successors, and
2. The **shape property** that the tree is complete (full except perhaps last level, in which case it should be filled from left to right).

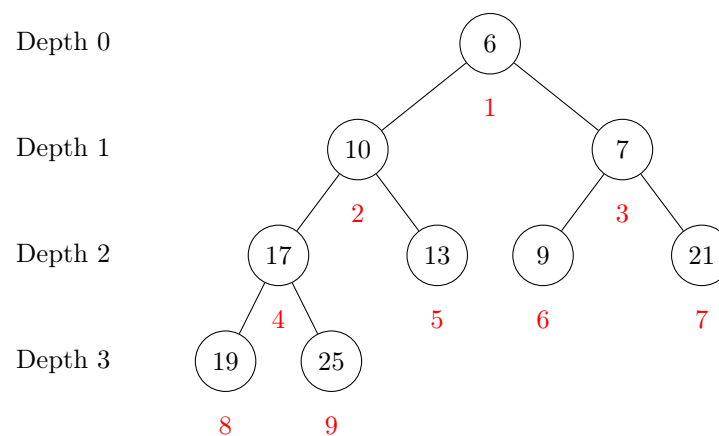

Figure 15: Tree structure of a binary heap, with red labels representing the indices of the array structure mentioned below.

We should conceptually think of a binary heap as an underlying binary tree, but it is actually usually implemented with an array, and we can create a map from the heap to the array with the following indices.

	6	10	7	17	13	9	21	19	25	
0	1	2	3	4	5	6	7	8	9	10

Figure 16: When 1-indexing, for node with index  $k$ , the left child is index  $2k$ , the right child is index  $2k + 1$ , and the parent is index  $k/2$  (where this is integer division).

Implementing peek is easy, since we just return the first index, but it can be quite tricky to maintain this invariant after an arbitrary sequence of add/remove operations.

1. To add values to a heap, we add to the first open position in the last level of the tree (to maintain the shape property), and then swap with the parent if the heap property is violated. If we are swapping with the parent at most  $\log(N)$  times, then the add property has  $O(\log(N))$  complexity.

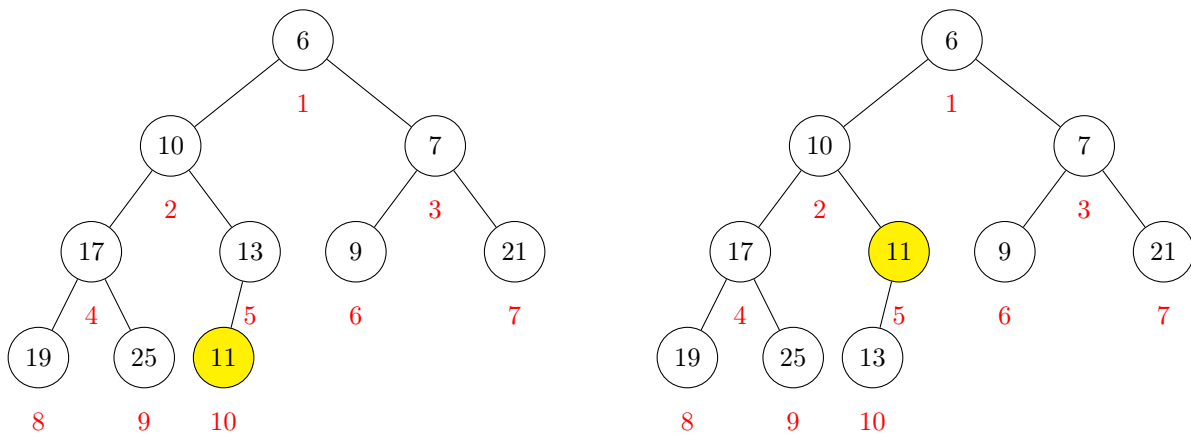

(a) Add the 11 node to the tree by inserting in the lowest depth, from left to right.

(b) Keep swapping the added node with its ancestor if the node is smaller.

Figure 17: Visual of how to add nodes to a heap.

2. We remove the first (minimal) value, we first replace the root with the last node in the heap, and while the heap property is violated, we swap with the smaller child. There are two choices, the left or right child, in which we can swap. But we must always swap with the **smaller child**, since we swapped with the bigger child, then this bigger child would be larger than the smaller one, violating the heap property. Since a complete binary tree always has height  $O(\log(N))$ , remove also "traverses" one root-leaf path, and so its runtime complexity is  $O(\log(N))$ , too. hi

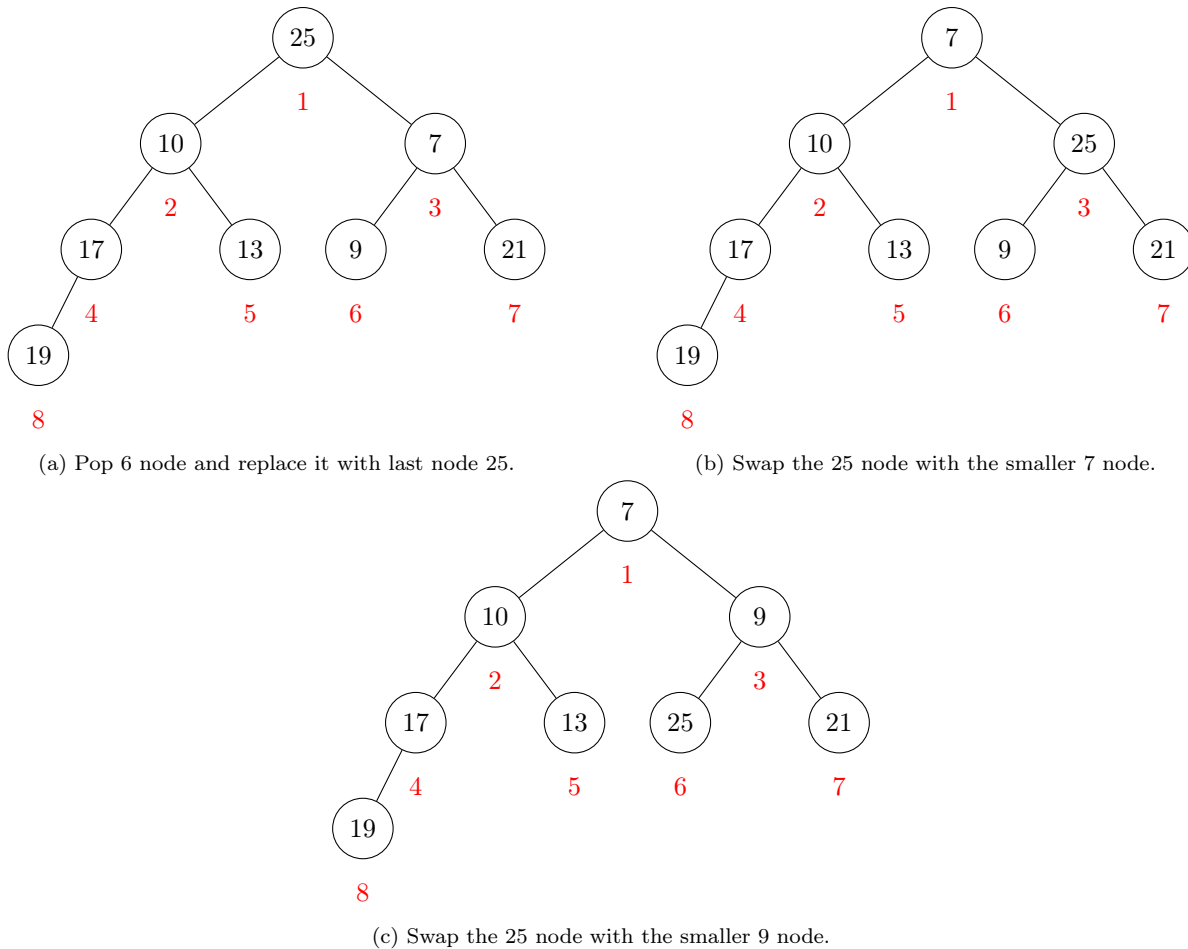

Figure 18: Binary heap restructuring during deletion operation

3. The decreaseKey operation just takes an arbitrary node and decreases its value to some other integer. In this case, it wouldn't violate the shape property, and to restore the heap property, we just put swap it with its parent if the new value is smaller than its parent, making this operation  $O(\log(N))$ .

#### Definition 3.8 (Priority Queues)

A priority queue simply adds things according to their priority. Every time we add an element, it looks at where the element should go to keep the list sorted. If we want to dequeue, then we just remove the first element of the list. If we implement a priority queue with a heap, we have

1. Adding a new value is  $O(\log N)$ .
2. Removing a specific value is  $O(\log N)$ .
3. Peek returns the minimal element and is  $O(1)$ .
4. Checking if a value is contained in a priority queue is ?.

### 3.5 Binary Search Trees

#### Definition 3.9 (Binary Search Tree)

A binary tree is a **binary search tree** if for every node, the left subtree values are all less than the node's value, and the right subtree values are all greater than the node's value. That is, the nodes are in order, and if we called `inOrder(root)` on the tree, then we would get a sorted list, which allows for efficient search.

Adding elements to a binary search tree is also very similar. But note that the order in which we add elements to the binary search tree will matter, since it can either make the tree **balanced** or **unbalanced**.

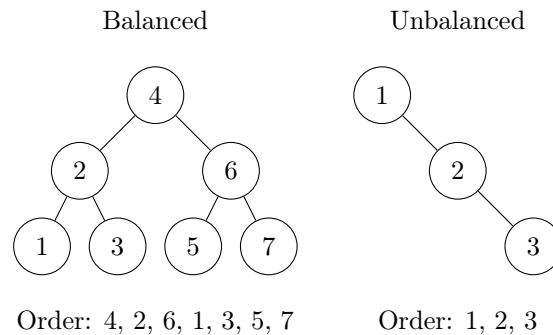

Figure 19: Comparison of balanced and unbalanced binary trees. In a balanced case, contains/add will be  $O(\log(N))$ , while in an unbalanced case, we will have  $O(N)$ .

#### Definition 3.10 (Binary Search)

Given that we have a sorted list (this is important!), we can search for the index of an element in  $O(\log n)$  time. We want the loop invariant "if the target is in the array/list, it is in the range [low, high]." Let us have a list of  $N$  elements, and at every step, we either

1. get our desired element and its index, or
2. cut down our search space by half

Now, we have learned how we can implement a priority queue using a binary heap. This is also possible to use a binary search tree, since it's easy to get the minimal element for adding and removing, but there are three things that make it difficult:

1. all elements must be unique
2. it is not array-based, and so uses more memory and higher constant factors on runtime
3. it is much harder to implement with guarantees that the tree will be balanced. This makes it difficult since if we want to search through a balanced BST, it is  $O(\log(N))$ , but if it turns out to be unbalanced, then it is  $O(N)$ .

Therefore, while a balanced tree may be efficient on average, in the worst case the linear complexity is not tolerable. Therefore, we must implement a binary search tree that will do extra work to ensure that they are approximately balanced. This is where *red-black trees*, which are a special type of binary search trees, come in.

**Definition 3.11 (Red-Black Tree)**

**Red-Black Trees** are binary search trees consisting of nodes that are labeled either red or black that satisfy the following properties:

1. The root is black
2. A red node cannot have red children
3. From any node, all paths to null descendants must have the same number of black nodes. (Null is considered to be a black node)

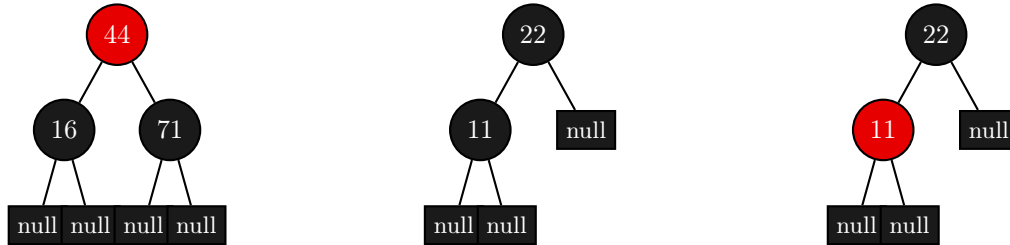

(a) Invalid: Root node is red, violating the property that the root must be black.

(b) Invalid: Path (22,null) has 2 black nodes, but path (22,11,null) has 3, violating the black-depth property.

(c) Valid: Root is black, reds have no red children, all paths from node to null have same black counts.

Figure 20: Examples and non-examples of red-black trees.

Remember that red black trees are also just binary search trees, and so some of the operations are the same.

1. contains (search) method is the exact same thing as BST
2. The add method needs to be slightly modified, since after we add, we need to make sure that the resulting tree is a red-black tree. This is done in three steps:
  - (a) Run the regular BST add
  - (b) Color the new node red
  - (c) Fix the tree to reestablish red-black tree properties. This is extremely complicated with different cases, but it all essentially uses some sort of recoloring and a (right or left) rotation of the tree.

Note that there are binary search trees that cannot be turned into a red-black tree.

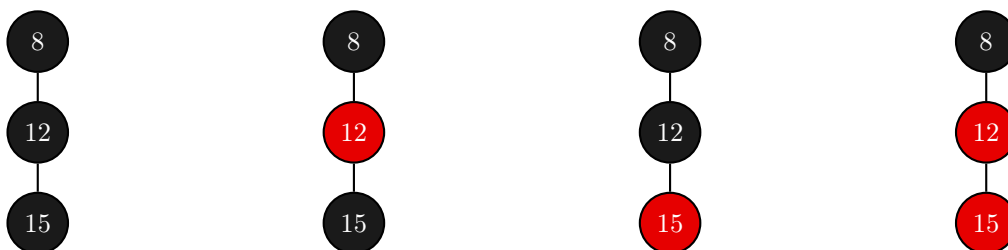

(a) Too many black nodes on right compared to left paths (b) Too many black nodes on right compared to left paths (c) Too many black nodes on right compared to left paths (d) Red node with red child not allowed

Figure 21: Examples of Red-Black Tree violations.

This is intentional because red-black tree properties guarantee approximate balance. If we can turn a binary search tree into a red-black tree, then it logically follows that the original BST was approximately balanced. Note that a red black tree does not make searching asymptotically faster in any way; it just takes care of the worst-case.

### 3.6 Tries

## 4 Brute Force Algorithms

So far we have only dealt with algorithms that interact directly with a data structure as an operation. While this is very useful, it's not very fun. Beginning from here, we will consider real-world problems and use data structures more as a *tool* rather than the primary object of study.

The first step to building an efficient correct algorithm is to build a correct algorithm, and that is what we focus on here. There are two types of efficiency we have to focus on here. The first is time complexity, which we have done so far. The second refers to the size of the data structures that we use. Obviously we don't want to use a list of size 1000 if a list of size 10 is needed, and so this is referred to as *memory complexity*, which will also be mentioned.

Many of these problems will be revisited, either with more efficient solutions or proofs that these brute-force methods are the best that we can do.

### 4.1 Basic Arithmetic

In here, we use basic deductions from elementary algebra to give us a starting point at which we analyze fundamental arithmetic algorithms. When we do addition of two numbers, we learn in elementary school to add the least significant digits first and continue on, carrying the 1 over to the next digit if needed. This is essentially an algorithm. We are also used to doing this in base 10, but we can do it in any base. For reasons that we will see in my computer architecture notes, I will conduct this in base 2.

#### Algorithm 4.0 (Adding Two Integers)

Given two integers  $x, y$  with  $n$  bits each, we can add them in the following way.

**Require:**  $x = x_n \dots x_1, y = y_n \dots y_1$

```

1: procedure ADD( $x, y$ )
2:    $z = [0, \dots, 0]$  of size  $n + 1$            ▷Initialize array to store result.
3:    $c = 0$                                      ▷Stores value to carry over
4:   for  $i \leftarrow 1, \dots, n$  do
5:      $z_i \leftarrow x_i + y_i + c$ 
6:     if  $z_i > 1$  then
7:        $z_i \leftarrow z_i - 2$ 
8:        $c \leftarrow 1$ 
9:     else
10:       $c \leftarrow 0$ 
11:    end if
12:  end for
13:  if  $c > 0$  then
14:     $z[n + 1] \leftarrow 1$ 
15:  end if
16:  return  $z_{n+1}z_n \dots z_1$ 
17: end procedure

```

This gives us a total complexity of  $\Theta(n)$ , since we are looping over the  $n$  bits, plus a constant operation to check for the most significant digit. It also has a memory complexity of  $O(n)$ .<sup>a</sup>

<sup>a</sup>Note that we have also used addition in our add function! In here, note that  $x_i, y_i, c$  are all either 0 or 1, so it will take at most constant time to add all of them. Hence we can treat these addition as  $\Theta(1)$ .

By the same logic, the time and memory complexity of subtraction are both also  $\Theta(n)$  in the number of bits  $n$ .

**Algorithm 4.0 (Multiplying Two Integers)**

Given two integers  $x, y$  with  $n$  bits each, we can multiply them in the following way.

**Require:**  $x = x_n \dots x_1, y = y_n \dots y_1$

```

1: procedure MULTIPLY( $x, y$ )
2:    $z = [0, \dots, 0]$  of size  $2n$                                 ▷Initialize array to store result.
3:   for  $i \leftarrow 1, \dots, n$  do
4:     if  $y_i = 1$  then
5:        $carry \leftarrow 0$ 
6:       for  $j \leftarrow 1, \dots, n$  do
7:          $pos \leftarrow i + j - 1$                                 ▷Position in result
8:          $sum \leftarrow z_{pos} + x_j + carry$ 
9:          $z_{pos} \leftarrow sum \bmod 2$ 
10:         $carry \leftarrow \lfloor sum/2 \rfloor$ 
11:      end for
12:       $z_{i+n} \leftarrow carry$ 
13:    end if
14:  end for
15:  return  $z_{2n}z_{2n-1} \dots z_1$ 
16: end procedure

```

This algorithm has a time complexity of  $O(n^2)$ , since for each bit of  $y$  we potentially need to perform  $n$  additions. The space complexity is  $O(n)$  to store the result, which can be up to  $2n$  bits long.

**Algorithm 4.0 (Integer Division and Modulus)**

Given two non-negative integers, a dividend  $x$  and a divisor  $y$ , we can compute the quotient  $\lfloor x/y \rfloor$  and remainder  $r$  such that  $x = y \cdot \lfloor x/y \rfloor + r$  and  $0 \leq r < y$ . This algorithm implements long division in binary, processing the dividend bit by bit from most to least significant.

**Require:**  $x \geq 0$  with  $n$  bits,  $y > 0$  with  $m$  bits

▷Input: dividend  $x$  and divisor  $y$

```

1: procedure DIVIDE( $x, y$ )
2:   if  $y = 0$  then                                           ▷Check for division by zero
3:     return error                                           ▷Division by zero is undefined
4:   end if
5:   if  $x < y$  then                                           ▷Handle case where result is 0
6:     return  $(0, x)$                                            ▷Quotient is 0, remainder is  $x$ 
7:   end if
8:    $quotient \leftarrow 0$                                        ▷Initialize quotient
9:    $remainder \leftarrow 0$                                        ▷Initialize remainder
10:  for  $i \leftarrow n, n-1, \dots, 1$  do                         ▷Process bits from most to least significant
11:     $remainder \leftarrow 2 \cdot remainder + x_i$                  ▷Shift remainder left and add next bit
12:    if  $remainder \geq y$  then                                   ▷If remainder is at least the divisor
13:       $remainder \leftarrow remainder - y$                        ▷Subtract divisor from remainder
14:       $quotient \leftarrow quotient \cdot 2 + 1$                  ▷Set current bit of quotient to 1
15:    else
16:       $quotient \leftarrow quotient \cdot 2$                        ▷Set current bit of quotient to 0
17:    end if
18:  end for
19:  return  $(quotient, remainder)$                                ▷Return both quotient and remainder
20: end procedure

```

The time complexity is  $O(n \cdot m)$ , where  $n$  is the number of bits in the dividend and  $m$  is the number of bits in the divisor. This is because for each of the  $n$  bits, we may need to perform a subtraction operation which takes  $O(m)$  time. The space complexity is  $O(n)$  to store the quotient and  $O(m)$  to

store the remainder, for a total of  $O(n + m)$ .

#### Algorithm 4.0 (Integer Exponentiation)

Given an integer  $x$  with  $n$  bits and a non-negative integer exponent  $y$ , we can compute  $x^y$  efficiently using the binary exponentiation method.

**Require:**  $x$  with  $n$  bits,  $y = y_m \dots y_1$  with  $m$  bits ▷Input: base  $x$  and exponent  $y$  in binary

```

1: procedure EXPONENTIATE( $x, y$ )
2:    $result \leftarrow 1$  ▷Initialize result to identity element for multiplication
3:    $base \leftarrow x$  ▷Initialize base to the original input value
4:   for  $i \leftarrow 1, \dots, m$  do ▷Iterate through each bit of the exponent
5:     if  $y_i = 1$  then ▷If current bit is set (equals 1)
6:        $result \leftarrow \text{Multiply}(result, base)$  ▷Include current power in the result
7:     end if
8:      $base \leftarrow \text{Multiply}(base, base)$  ▷Square the base for next iteration (creating  $x^{2^i}$ )
9:   end for
10:  return  $result$  ▷Return the final computed value  $x^y$ 
11: end procedure

```

This algorithm has a time complexity of  $O(m \cdot n^2)$ , where  $m$  is the number of bits in the exponent and  $n$  is the number of bits in the base. This is because we perform at most  $m$  multiplications, and each multiplication (using the standard algorithm) takes  $O(n^2)$  time. The space complexity is  $O(n \cdot 2^m)$  in the worst case, as the result can grow exponentially with the exponent value.

#### Algorithm 4.0 (Factorial)

Given a non-negative integer  $n$ , we can compute  $n!$  as such.

**Require:**  $n \geq 0$  ▷Input: non-negative integer  $n$

```

1: procedure FACTORIAL( $n$ )
2:   if  $n = 0$  or  $n = 1$  then ▷Handle base cases
3:     return 1 ▷ $0! = 1! = 1$  by definition
4:   end if
5:    $result \leftarrow 1$  ▷Initialize result
6:   for  $i \leftarrow 2, 3, \dots, n$  do ▷Multiply by each integer from 2 to  $n$ 
7:      $result \leftarrow \text{Multiply}(result, i)$  ▷Accumulate product
8:   end for
9:   return  $result$  ▷Return  $n!$ 
10: end procedure

```

This algorithm implements the direct definition of factorial by iteratively multiplying all integers from 2 to  $n$ . The time complexity is  $O(n \cdot s^2)$ , where  $n$  is the input value and  $s$  is the maximum number of bits needed to represent the intermediate results (which can be up to  $O(\log(n!)) = O(n \log n)$  bits). This is because we perform  $O(n)$  multiplications, and each multiplication between numbers with  $s$  bits takes  $O(s^2)$  time using the standard algorithm. The space complexity is  $O(s) = O(n \log n)$  to store the result, which grows very rapidly with  $n$ .

## 4.2 Lists

### Algorithm 4.0 (Max and Min of List)

Given a list of  $n$  elements  $A = [a_1, a_2, \dots, a_n]$ , we can find both the maximum and minimum values in the following way.

**Require:**  $A = [a_1, a_2, \dots, a_n]$  ▷Input: list of  $n$  elements

```

1: procedure FINDMAXANDMIN( $A$ )
2:   if length of  $A = 0$  then ▷Handle empty list
3:     return (undefined, undefined)
4:   end if
5:    $max \leftarrow A[1]$  ▷Initialize max with first element
6:    $min \leftarrow A[1]$  ▷Initialize min with first element
7:   for  $i \leftarrow 2, 3, \dots, n$  do ▷Iterate through remaining elements
8:     if  $A[i] > max$  then ▷Update maximum if needed
9:        $max \leftarrow A[i]$ 
10:    end if
11:    if  $A[i] < min$  then ▷Update minimum if needed
12:       $min \leftarrow A[i]$ 
13:    end if
14:  end for
15:  return ( $max, min$ ) ▷Return both maximum and minimum
16: end procedure

```

The time complexity is  $\Theta(n)$  since we examine each element exactly once. The space complexity is  $O(1)$  as we only use a constant amount of extra space regardless of input size.

### Algorithm 4.0 (Bubble Sort)

Given a list of  $n$  elements  $A = [a_1, a_2, \dots, a_n]$ , we can sort them in ascending order using the bubble sort algorithm.

**Require:**  $A = [a_1, a_2, \dots, a_n]$  ▷Input: list of  $n$  elements

```

1: procedure BUBBLESORT( $A$ )
2:   for  $i \leftarrow 1, 2, \dots, n - 1$  do ▷Outer loop for passes
3:      $swapped \leftarrow false$  ▷Flag to track if any swaps occurred
4:     for  $j \leftarrow 1, 2, \dots, n - i$  do ▷Inner loop for comparisons
5:       if  $A[j] > A[j + 1]$  then ▷Compare adjacent elements
6:         Swap  $A[j]$  and  $A[j + 1]$  ▷Swap if they are in wrong order
7:          $swapped \leftarrow true$  ▷Set flag to indicate a swap occurred
8:       end if
9:     end for
10:    if  $swapped = false$  then ▷If no swaps occurred in this pass
11:      break ▷Array is already sorted, exit early
12:    end if
13:  end for
14:  return  $A$  ▷Return sorted list
15: end procedure

```

The time complexity is  $O(n^2)$  in the worst case when the array is in reverse order. In the best case (already sorted), the complexity is  $\Theta(n)$  due to the early exit optimization. The space complexity is  $O(1)$  as it sorts in-place using only a constant amount of extra space.

**Algorithm 4.0 (Binary Search)**

Given a sorted list of  $n$  elements  $A = [a_1, a_2, \dots, a_n]$  and a target value  $x$ , we can efficiently search for  $x$  in  $A$  using binary search.

**Require:**  $A = [a_1, a_2, \dots, a_n]$  (sorted), target value  $x$  ▷Input: sorted list and target

```

1: procedure BINARYSEARCH( $A, x$ )
2:    $left \leftarrow 1$  ▷Initialize left pointer to start of the list
3:    $right \leftarrow n$  ▷Initialize right pointer to end of the list
4:   while  $left \leq right$  do ▷Continue while search space is valid
5:      $mid \leftarrow \lfloor (left + right)/2 \rfloor$  ▷Calculate middle index
6:     if  $A[mid] = x$  then ▷Target found
7:       return  $mid$  ▷Return the index where target was found
8:     end if
9:     if  $A[mid] < x$  then ▷If target is in right half
10:       $left \leftarrow mid + 1$  ▷Update left pointer to search right half
11:     else ▷If target is in left half
12:       $right \leftarrow mid - 1$  ▷Update right pointer to search left half
13:     end if
14:   end while
15:   return  $-1$  ▷Target not found in the list
16: end procedure

```

The time complexity is  $O(\log n)$  since each comparison eliminates approximately half of the remaining elements. The space complexity is  $O(1)$  for the iterative implementation shown here, as it uses only a constant amount of extra space regardless of input size.

**4.3 Stack, Queues, Heaps****4.4 Cryptography****Algorithm 4.0 (GCD of Two Numbers)**

The following is Euclid's algorithm for finding the GCD of two integers. It uses a recursive strategy.

```

1: procedure GCD( $a, b$ ) ▷Compute greatest common divisor of  $a$  and  $b$ 
2:   if  $a = b$  then ▷Base case: numbers are equal
3:     return  $a$ 
4:   else if  $a > b$  then ▷First recursive case:  $a$  is larger
5:     return GCD( $a - b, b$ )
6:   else ▷Second recursive case:  $b$  is larger
7:     return GCD( $a, b - a$ )
8:   end if
9: end procedure

```

Example:  $\text{GCD}(63, 210) = 21$

Note that in order to determine if a number  $n$  is prime, we must check all prime number  $p < \sqrt{n}$ . This gives us the brute force primality testing algorithm.

**Algorithm 4.0 (Primality Testing)**

Given a positive integer  $n > 1$ , we can determine whether it is prime as follows.

**Require:**  $n > 1$  ▷Input: integer to test for primality

```

1: procedure ISPRIME( $n$ )

```

```

2:  if  $n = 2$  or  $n = 3$  then                                ▷Handle known small primes
3:      return true
4:  end if
5:  if  $n \bmod 2 = 0$  or  $n \bmod 3 = 0$  then                    ▷Check divisibility by small primes
6:      return false
7:  end if
8:   $i \leftarrow 5$                                            ▷Start checking from 5
9:  while  $i \cdot i \leq n$  do                                ▷Check potential divisors up to  $\sqrt{n}$ 
10:     if  $n \bmod i = 0$  or  $n \bmod (i + 2) = 0$  then        ▷Check  $i$  and  $i + 2$  (covers all primes  $> 3$ )
11:         return false                                    ▷Found a divisor, so not prime
12:     end if
13:      $i \leftarrow i + 6$                                     ▷Skip to next potential prime pair
14:  end while
15:  return true                                             ▷No divisors found, so number is prime
16: end procedure

```

This algorithm has a time complexity of  $O(\sqrt{n})$ , as we check potential divisors up to  $\sqrt{n}$ . The optimization of checking only numbers of the form  $6k \pm 1$  (which covers all primes  $> 3$ ) reduces the constant factor but does not change the asymptotic complexity. The space complexity is  $O(1)$  as we use only a constant amount of extra space.

#### Algorithm 4.0 (Integer Factorization)

Given a positive integer  $n > 1$ , we can find its prime factorization as follows.

```

Require:  $n > 1$                                            ▷Input: integer to factorize
1: procedure PRIMEFACTORIZE( $n$ )
2:    $factors \leftarrow$  empty list                               ▷Initialize list to store prime factors
3:   while  $n \bmod 2 = 0$  do                                    ▷Extract all factors of 2
4:     Add 2 to  $factors$ 
5:      $n \leftarrow n/2$ 
6:   end while
7:   while  $n \bmod 3 = 0$  do                                    ▷Extract all factors of 3
8:     Add 3 to  $factors$ 
9:      $n \leftarrow n/3$ 
10:  end while
11:   $i \leftarrow 5$                                            ▷Start checking from 5
12:  while  $i \cdot i \leq n$  do                                ▷Check potential prime factors up to  $\sqrt{n}$ 
13:     while  $n \bmod i = 0$  do                                ▷Extract all factors of current prime
14:       Add  $i$  to  $factors$ 
15:        $n \leftarrow n/i$ 
16:     end while
17:     while  $n \bmod (i + 2) = 0$  do                            ▷Extract all factors of next potential prime
18:       Add  $(i + 2)$  to  $factors$ 
19:        $n \leftarrow n/(i + 2)$ 
20:     end while
21:      $i \leftarrow i + 6$                                     ▷Skip to next potential prime pair
22:  end while
23:  if  $n > 1$  then                                          ▷If remaining number is greater than 1, it's prime
24:    Add  $n$  to  $factors$ 
25:  end if
26:  return  $factors$                                           ▷Return list of prime factors
27: end procedure

```

This algorithm has a time complexity of  $O(\sqrt{n})$  in the worst case, as we check potential prime factors up to  $\sqrt{n}$ . Similar to the primality test, we use the optimization of checking only numbers of the form  $6k \pm 1$  after handling the factors of 2 and 3 explicitly. The space complexity is  $O(\log n)$  for storing the prime factors, since a number can have at most  $O(\log n)$  prime factors.

## 4.5 Matrix Operations

### Algorithm 4.0 (Matrix Multiplication)

Given two matrices  $A$  of size  $m \times n$  and  $B$  of size  $n \times p$ , we can compute their product  $C = A \times B$  of size  $m \times p$  as follows.

**Require:**  $A$  is an  $m \times n$  matrix,  $B$  is an  $n \times p$  matrix      ▷Input: compatible matrices to multiply

```

1: procedure MATRIXMULTIPLY( $A, B$ )
2:    $m \leftarrow$  number of rows in  $A$ 
3:    $n \leftarrow$  number of columns in  $A$                                 ▷Also number of rows in  $B$ 
4:    $p \leftarrow$  number of columns in  $B$ 
5:   Initialize matrix  $C$  of size  $m \times p$  with zeros                    ▷Initialize result matrix
6:   for  $i \leftarrow 1, 2, \dots, m$  do                                  ▷Iterate through rows of  $A$ 
7:     for  $j \leftarrow 1, 2, \dots, p$  do                               ▷Iterate through columns of  $B$ 
8:       for  $k \leftarrow 1, 2, \dots, n$  do                            ▷Compute dot product of row  $i$  of  $A$  and column  $j$  of  $B$ 
9:          $C[i][j] \leftarrow C[i][j] + A[i][k] \times B[k][j]$            ▷Accumulate sum of products
10:      end for
11:    end for
12:  end for
13:  return  $C$                                                        ▷Return the product matrix
14: end procedure

```

This algorithm implements the standard matrix multiplication with three nested loops. The time complexity is  $O(mnp)$ . The space complexity is  $O(mp)$  for storing the result matrix.

### Algorithm 4.0 (Matrix Inversion)

Given a non-singular square matrix  $A$  of size  $n \times n$ , we can compute its inverse  $A^{-1}$  using Gaussian elimination with the Gauss-Jordan method.

**Require:**  $A$  is an  $n \times n$  non-singular matrix      ▷Input: invertible square matrix

```

1: procedure MATRIXINVERSE( $A$ )
2:    $n \leftarrow$  number of rows/columns in  $A$ 
3:   Create augmented matrix  $[A|I]$  by appending the identity matrix  $I$  of size  $n \times n$  to  $A$ 
4:   for  $i \leftarrow 1, 2, \dots, n$  do                                  ▷Forward elimination phase
5:     Find pivot: maximum absolute value in column  $i$  from rows  $i$  to  $n$ 
6:     if pivot = 0 then
7:       return error                                              ▷Matrix is singular and not invertible
8:     end if
9:     Swap current row  $i$  with pivot row if needed
10:    Divide row  $i$  by  $A[i][i]$  to make the pivot element 1
11:    for  $j \leftarrow 1, 2, \dots, n$  where  $j \neq i$  do                ▷Eliminate other entries in column  $i$ 
12:       $factor \leftarrow A[j][i]$ 
13:      for  $k \leftarrow i, i + 1, \dots, 2n$  do                        ▷Update augmented matrix row
14:         $A[j][k] \leftarrow A[j][k] - factor \times A[i][k]$ 
15:      end for
16:    end for
17:  end for

```

```

18:   Extract  $A^{-1}$  from the right half of the augmented matrix  $[I|A^{-1}]$ 
19:   return  $A^{-1}$ 
20: end procedure

```

This algorithm implements the Gauss-Jordan elimination method for matrix inversion. The time complexity is  $O(n^3)$  due to the three nested loops, and the space complexity is  $O(n^2)$  for storing the augmented matrix. The algorithm transforms the left half of the augmented matrix into the identity matrix, which simultaneously transforms the right half into the inverse matrix.

#### Algorithm 4.0 (Eigendecomposition)

Given a diagonalizable square matrix  $A$  of size  $n \times n$ , we can compute its eigenvalues and eigenvectors using the power iteration and deflation approach.

**Require:**  $A$  is an  $n \times n$  diagonalizable matrix ▷Input: diagonalizable square matrix

```

1: procedure EIGENDECOMPOSITION( $A$ )
2:    $n \leftarrow$  number of rows/columns in  $A$ 
3:   Initialize empty lists eigenvalues and eigenvectors
4:    $A_{current} \leftarrow A$  ▷Matrix for deflation process
5:   for  $i \leftarrow 1, 2, \dots, n$  do
6:     Initialize random vector  $v$  of size  $n - i + 1$  with unit norm
7:      $prev\_lambda \leftarrow 0$ 
8:      $lambda \leftarrow 1$ 
9:     while  $|lambda - prev\_lambda| > \epsilon$  do ▷Power iteration until convergence
10:       $prev\_lambda \leftarrow lambda$ 
11:       $w \leftarrow A_{current} \times v$  ▷Matrix-vector multiplication
12:       $lambda \leftarrow$  dominant component of  $w$ 
13:       $v \leftarrow w / \|w\|$  ▷Normalize vector
14:     end while
15:     Add  $lambda$  to eigenvalues
16:     Add  $v$  to eigenvectors
17:      $A_{current} \leftarrow$  Deflate  $A_{current}$  by removing the influence of  $\lambda$  and  $v$  ▷Deflation:
        $A_{current} = A_{current} - \lambda \times v \times v^T$ 
18:   end for
19:   Construct diagonal matrix  $\Lambda$  with eigenvalues on the diagonal
20:   Construct matrix  $V$  with eigenvectors as columns
21:   return  $(\Lambda, V)$  ▷Return eigenvalue matrix and eigenvector matrix
22: end procedure

```

This algorithm implements a simplified version of eigendecomposition using power iteration and deflation. The time complexity is  $O(k \times n^3)$  where  $k$  is the average number of iterations needed for convergence. The space complexity is  $O(n^2)$  for storing the matrices. In practice, more sophisticated methods like the QR algorithm are preferred for numerical stability, but the power method illustrates the basic approach.

Given the eigendecomposition is approximately  $O(n^3)$ , we can also see that computing the singular value decomposition or matrix exponentials are also  $O(n^3)$ .

## 5 Greedy Algorithms

Greedy algorithms are easy to implement and easy to conceptualize, but they are often not correct. So the only interest in them is proving if they are correct. We have done greedy algorithms like Dijkstra and finding MSTs. Every step, greedy algorithms make an irrevocable decision of what to do and cannot undo it. That is, we cannot backtrack. In fact, some algorithms like Kruskal's algorithm for MSTs is precisely a greedy algorithm.

### Example 5.1 (Interval Scheduling)

Let there be 1 classroom and  $n$  courses, each with a start and end time  $(s_i, e_i)$ . We want to find the largest subset of courses that can be scheduled in a day such that they don't overlap. There are two things we want to do. How do we code this up? How do we show that a greedy algorithm will give a correct answer? Two greedy approaches are as follows.

1. Sort them by the start times, and add them as long as they do not overlap with what you have. This will not work.
2. Sort them by the time interval lengths and keep adding them as long as they do not overlap with what you have. This will not work either.

It turns out that if we sort based on finish time, this will work. So why is this correct? Assume that the first  $k$  decisions of this greedy algorithm are correct. Then, to find the next interval that we will include, the optimal algorithm must choose one that does not overlap with what we have. This is good since we do the same. The second part is that the next added interval must have the smallest end time  $t$  from all viable left intervals. Assume that it was not and that the optimal next interval had end time  $s > t$ . Then, the next interval must start after  $s$ , but this also starts after  $t$ , so we are sacrificing unnecessary extra space. An optimal solution with the endpoint at  $s$  can also be constructed with the same interval ending at  $t$  without anything to lose.

#### Algorithm 1 Find Max Classes to Fit into 1 Room

**Require:** classes  $C = \{(s_i, e_i)\}_i$  of type List[tuple(int, int)]

```

function SCHEDULE(C)
  res ← []
  sort C by increasing end time
  for  $s, e \in C$  do
    if  $s < \text{res}[-1][-1]$  then                                ▷If start overlaps with previous end time
      continue
    end if
    add  $(s, e)$  to res                                       ▷Otherwise add class to final schedule
  end for
  return res
end function

```

To get the run time, the sorting takes  $O(n \log n)$  time and iterating is  $O(n)$ , so a total of  $O(n \log n)$  time.

### Example 5.2 (Classroom Scheduling)

A slightly more practical example is that you have  $n$  classes and you want to minimize the number of classrooms  $m$ . For this, you can really use any order. The general idea is

1. Consider intervals in increasing start time  $s_i$ .
2. If it can be scheduled in an existing classroom, then schedule it there.
3. If not, then open a new classroom.

Even then, we can conduct a line search through all the time periods, incrementing the current number

of classes if an incoming time is a start time and decrementing if it is an end time. We report the max  $\Delta$  over all times.

This algorithm is correct since by definition,  $\Delta$  is the lower bound for the number of classrooms needed and the greedy algorithm attains it. The greedy algorithm reports  $\Delta$  since if it reported  $\Delta+1$  classroom, then at some time  $t$  it opened the  $\Delta+1$ th classroom. But this is impossible since this must mean that there are  $\Delta+1$  classrooms concurrently in use, contradicting our assumption that  $\Delta$  is the optimal solution.

---

**Algorithm 2** Minimizing Number of Rooms With  $n$  Classes (Leetcode 253, Meeting Rooms II)

---

**Require:** classes  $C = \{(s_i, e_i)\}_i$  of type `List[tuple(int, int)]`

```

function MEETINGROOMS( $C$ )
  start  $\leftarrow$  all start times sorted increasing
  end  $\leftarrow$  all end times sorted increasing
  res  $\leftarrow$  0
  count  $\leftarrow$  0
  s, e  $\leftarrow$  0
  while s < len(start) do
    if start[s] == end[e] then
      s += 1, e += 1
    else if start[s] > end[e] then
      e += 1, count -= 1
    else if start[s] < end[e] then
      s += 1, count += 1
      res = max(res, count)
    end if
  end while
  return res
end function

```

$\triangleright$ Our max classes count  
 $\triangleright$ Our curr. classes count  
 $\triangleright$ pointers for start, end  
 $\triangleright$ Don't need to check for end since  
 $\triangleright$ start will always finish faster.  
 $\triangleright$ One started and one ended, so don't change  
 $\triangleright$ One ended, so decrement count  
 $\triangleright$ One started, so increment count  
 $\triangleright$ Update res if we got past it

---

The runtime is  $O(n \log n)$ , which is to sort. However, you don't even need to sort since you can go through all intervals in any order and place it in an existing classroom or open a new classroom.

The next one isn't as trivial, but requires us to devise a custom sorting method by comparing two sequences with a swap difference.

**Example 5.3 (Quiz Problem)**

Suppose you have  $n$  questions with question  $i$  having reward  $r_i$ , but the probability that you get it correct is  $p_i$ . You keep collecting the reward until you get one question wrong, and the game terminates. What order would you answer the questions in?

Suppose we have  $q = (10, 5)$  and  $r = (0.1, 0.2)$ .

1. If you choose the first and then second, then the expected return is

$$10 \cdot 0.1 + 5 \cdot 0.1 \cdot 0.2 = 1.1 \quad (40)$$

2. If you choose the second and then first, then the expected return is

$$5 \cdot 0.2 + 10 \cdot 0.1 \cdot 0.2 = 1.2 \quad (41)$$

Clearly, finding all possibilities is too computationally expensive since it increases exponentially w.r.t.  $n$ . Intuitively, if I have a question with a high reward, I want to answer it first, but if I have a low probability of getting it correctly, then I can't answer future questions if I get it wrong. So I have to balance these two forces. So we want to sort the score of each question with some function  $f(r_i, p_i)$ , which is increasing in both  $r_i$  and  $p_i$ . It is not  $r_i p_i$ , but this is a good start.

Rather, we can take a different approach. Assume that the tuples were sorted in some order, but this was not the optimal order. Then this indicates that we can swap to adjacent elements and it will get a better order. This is really like bubble sort, and now we need to find out the conditions on which it can be improved.

1. If we answer  $q_1 \rightarrow q_2 \rightarrow q_3 \dots$ , our expected reward is

$$\mathbb{E}[R] = r_1p_1 + r_2p_1p_2 + r_3p_1p_2p_3 \quad (42)$$

2. If we swap  $q_2$  and  $q_3$  and answer  $q_1 \rightarrow q_3 \rightarrow q_2 \dots$ , then our expected reward is

$$\mathbb{E}[R] = r_1p_1 + r_3p_1p_3 + r_2p_1p_2p_3 \quad (43)$$

Note that the swap does not affect higher order terms. Doing some algebra, the swap is better iff

$$r_2p_2(1 - p_3) < r_3p_3(1 - p_2) \implies \frac{r_2p_2}{1 - p_2} < \frac{r_3p_3}{1 - p_3} \quad (44)$$

where the final swap saves computational time since we can compute for a single element rather than comparing pairwise elements. So, we sort it (in descending order!) according to these values to maximize this value. Note that the numerator measures your expected reward, while the denominator measures the probability of you screwing up.

Not all greedy problems admit to scoring functions however. This was just one example.

#### Example 5.4 (Minimizing Max Lateness)

Suppose there are  $n$  jobs that all come in at once at time 0, with job  $j$  having length  $p_j$  and deadline  $d_j$ . We want to schedule the order of jobs on one machine that can handle one job at a time, where you must minimize the maximum lateness, where the lateness of job  $i$  is  $\max\{f_i - d_i, 0\} = [f_i - d_i]^+$ . For example, given jobs  $(p, d) = \{(10, 9), (8, 11)\}$ , we can run it in two ways.

1. Running 1 then 2. The first job finishes at 10 and the second at 18. The lateness is  $10 - 9 = 1$  and  $18 - 11 = 7$  respectively, so the maximum lateness is 7.
2. Running 2 then 1. The first job finishes at 8 and the second at 18. The lateness is 0 and  $18 - 9 = 9$ , so the maximum lateness is 9.

Therefore,  $1 \rightarrow 2$  beats  $2 \rightarrow 1$ . Clearly, brute forcing this over  $N!$  jobs orderings is unfeasible, but there is a greedy approach to this. We can

1. schedule jobs in increasing order of deadlines.
2. try to exchange by taking a sequence, swapping it, and computing the score like we did for previous examples.

Both lead to the same score/principle that we should schedule jobs in increasing order of deadlines. Let's prove this by taking jobs  $i$  and  $j$ , where  $d_j \leq d_i$ . Then, if we schedule  $i \rightarrow j$ , then we have

$$l_i = [t + p_i - d_i]^+ \quad (45)$$

$$l_j = [t + p_i + p_j - d_j]^+ \quad (46)$$

with  $l_j$  being the greatest late time. If we did  $j \rightarrow i$ , then we have

$$\hat{l}_j = [t + p_j - d_j]^+ \quad (47)$$

$$\hat{l}_i = [t + p_i + p_j - d_i]^+ \quad (48)$$

with  $\hat{l}_i$  being the greatest late time. But this is a good sacrifice since we can see that both

$$l_j > \hat{l}_j \text{ and } l_j > \hat{l}_i \quad (49)$$

meaning that if we swap, then we will decrease the lateness of  $j$  at the smaller cost of increasing that of  $i$ . Therefore,  $j \rightarrow i$  is better. Note that even though the end times of the second job will always be

the same between the two choices, starting with  $j$  will give a later deadline time. So this means that in the optimal solution, we have to place them in this order of deadlines since we can always improve them by swapping.

### Example 5.5 (Gift Wrapping a Convex Hull)

Given  $n$  points in  $\mathbb{R}^2$ , we want to find the subset of points on the boundary of its convex hull. We can intuit this by taking the bottom most point and imagine “wrapping” a string around the entire region.<sup>a</sup> Here’s a basic fact. If we have a point  $p_1 = (x_1, y_1)$  and we’re looking at  $p_2 = (x_2, y_2)$ , and then  $p_3 = (x_3, y_3)$  shows up, then we can look at the cross product

$$P = (x_2 - x_1)(y_3 - y_1) - (y_2 - y_1)(x_3 - x_1) \quad (50)$$

and if  $P > 0$ , then  $p_3$  is counterclockwise from  $p_2$ . The algorithm is as such.

1. You choose the bottommost point and label it  $p_1$ .
2. You construct a vector pointing to the right and start turning it counterclockwise until it hits the first point. This can be done by iterating through all of the  $n$  points and computing the angle.

$$\tan \theta = \frac{y_i - y_1}{x_i - x_1} \quad (51)$$

and the points with the smallest such tangent value will be the desired point, which will be  $\Theta(n)$ . We set this point to be  $p_2$  and claim that  $p_1, p_2$  is in the convex hull. This is true since all point must lie above the line  $p_1 p_2$ . Now you do the same thing with  $p_2$  starting with a vector facing to the right and rotating it left until it hits the first peg. Once you get to the topmost point, you can start the vector from the right and rotate it counterclockwise, but this is an implementation detail.

If your convex hull has  $L$  vertices, then this algorithm will have  $O(nL)$ , which will be  $O(n^2)$  worst case but if we sample uniformly, then we have  $L \approx \log n$  and on average it is  $O(n \log n)$ .

A lot of geometric algorithms is output sensitive.

<sup>a</sup>This is called the gift wrapping algorithm.

### Example 5.6 (Convex Hull with Graham Scan)

In fact, we can take a different approach and get  $O(n \log n)$  time.

1. You still start with  $p_1$  with the minimum y-coordinate and we sort in increasing  $\theta_i = \arctan \frac{y_i - y_1}{x_i - x_1}$ .
2. Then it will walk from  $p_i$  to  $p_{i+1}$  and check at  $p_{i+1}$  if it is on the convex hull or not.
  - (a) If you turned counterclockwise to go to  $p_{i+1}$  then it’s good and you’re on the convex hull.
  - (b) If you turned clockwise it is bad, and  $p_i$  is not on the convex hull, so remove  $p_i$ . However,  $p_{i-1}$  could also be clockwise as well, so you must backtrack and keep on removing points until you find a point  $p_j$  such that the previous turn is counterclockwise.

Note that this is implemented as a stack.

This can be calculated in  $O(1)$  by the previous cross product formula.

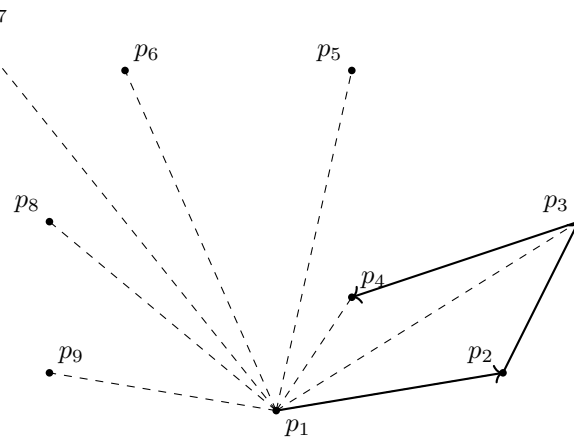

Figure 22: Visually, you start at the bottommost and rotate counterclockwise.

---

### Algorithm 3 Finding Convex Hull with Graham Scan

---

**Require:**  $p_1, \dots, p_n \in \mathbb{R}^2$   
**function** GRAHAM( $\mathbf{p}$ )  
   $s \leftarrow \text{stack}()$   
  push  $p_1, p_2$  onto  $s$   
  **for**  $i = 3, 4, \dots, n$  **do**  
    push  $p_i$  onto stack  
    **while** top 3 on stack are clockwise **do**  
      pop second from top point  
    **end while**  
  **end for**  
  **return**  $s$   
**end function**

---

Note that once we have 3 points, the first three in the stack will always be counterclockwise, so we will never need to check if there are enough points in the stack. Even in the beginning, the next point (third) added is guaranteed to be counterclockwise because of ordering. Note that even though we might do a bunch of pushes and pops, the maximum number of pushes we can do is  $n$  and pops is  $n$ , so this is  $O(n)$ . In fact, the bottleneck is the sorting, which is  $O(n \log n)$ , so the total runtime is  $O(n \log n)$ .

## 5.1 Huffman Coding

Now, let's talk about **Huffman encoding**. We already know about the ASCII encoding that encodes characters in 7 bits, for a total of  $2^7$  possibilities. The extended ASCII uses 8 bits, but all of these things use something called **fixed-length encoding** which uses a constant number of bits to encode any character. To compress something, we want to use **variable-length encoding**.

To decode something, the mapping from the characters to the bits must be injective, so we can define an inverse over its image. It turns out that if we an encoding for 3 characters, say

$$a \mapsto 1, b \mapsto 10, c \mapsto 11$$

then decoding 1011 is ambiguous since 1 is a prefix of the encoding for  $c$ . Therefore, we do not want one encoding to be the prefix of another. It turns out that we can avoid this conflict by encoding everything as a binary tree and setting all encodings as leaf nodes.

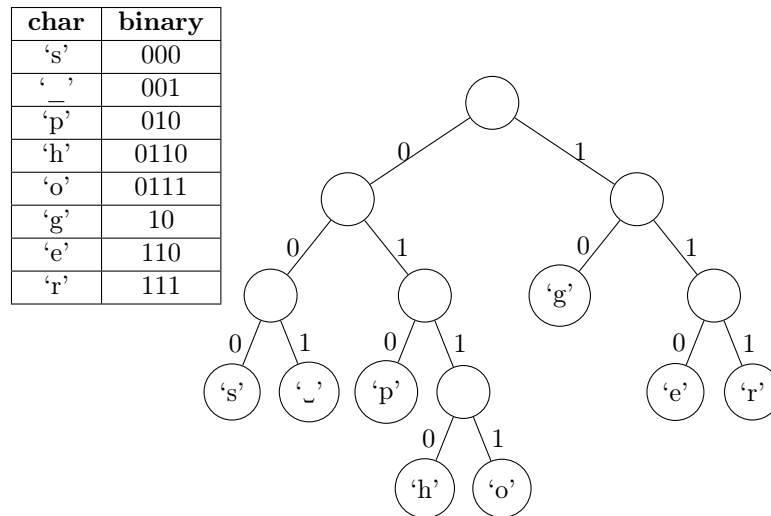

Figure 23: Tree-based representation of prefix codes showing how different characters are encoded with variable-length binary sequences. The convention uses 0 for left branches and 1 for right branches. The encoding for each character is the sequence of 0's and 1's on the path from root to leaf. Characters are placed at leaf nodes to ensure the prefix property, with values deeper in the tree requiring more bits than those higher up.

This makes sense since an encoding will be a prefix of another if and only if it is a parent of another. Furthermore, a greater depth of a character in the tree corresponds to a longer encoding. So, Huffman encoding tries to convert shorter characters to longer leaves and less recurrent characters into longer encodings. To decode a string of bits using a tree, we read the bit at a time to traverse left or right edge. When we reach a leaf, we decode the character and restart at root.

Now, we describe the greedy algorithm for building an optimal variable length encoding tree.

1. We take the document and compute the frequencies of all characters that we want to encode. We want to less frequent characters to be lower on the tree, and so we will build the tree up from the leaves.
2. We iteratively choose the lowest weight nodes to connect up to a new node with weight = sum of children.

We implement this using a priority queue.

#### Example 5.7

Let us go do an example of where we have the characters and frequencies

$$a \mapsto 30, b \mapsto 20, c \mapsto 10, d \mapsto 15, e \mapsto 40 \quad (52)$$

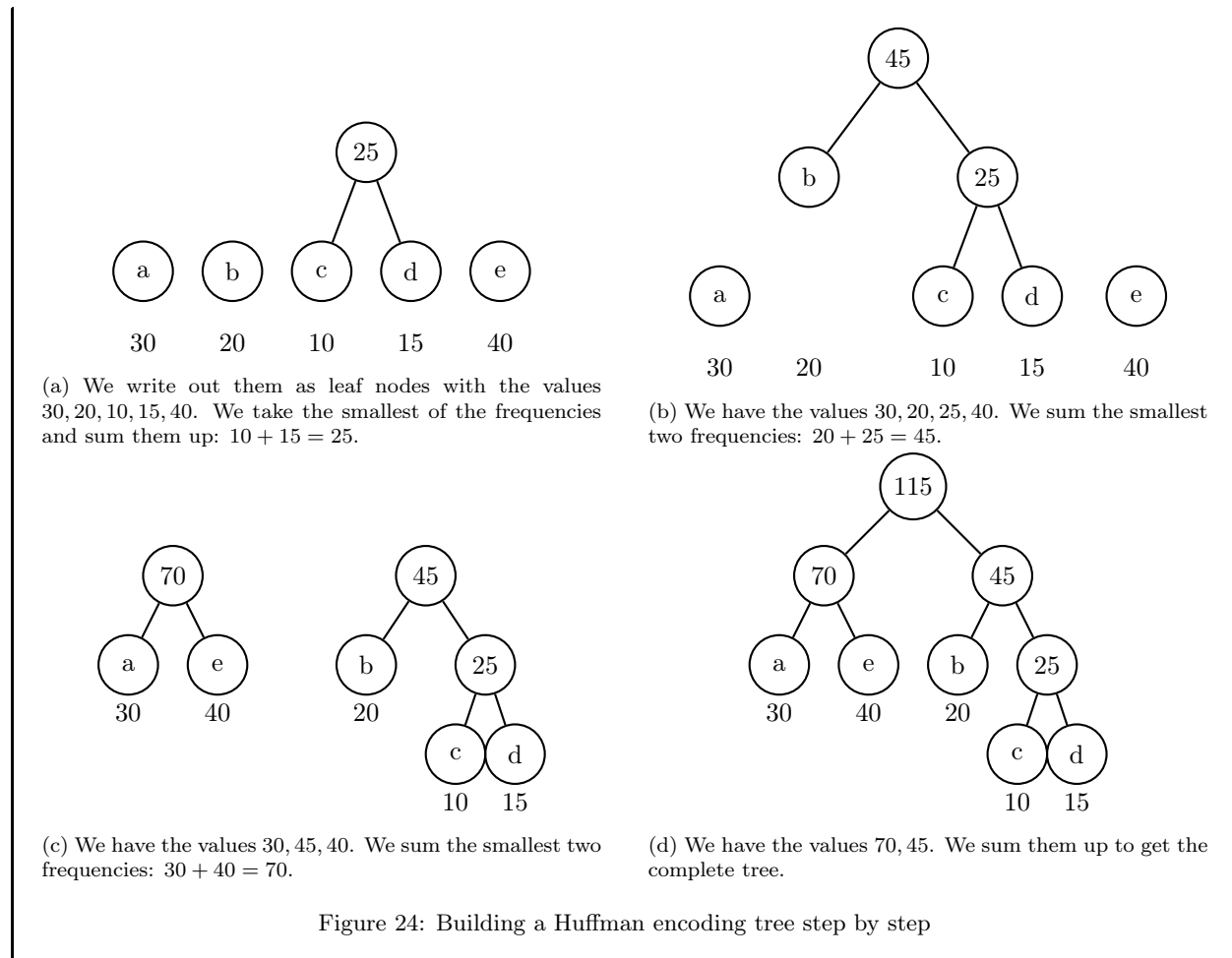

### Theorem 5.1 (Number of Nodes in Huffman Tree)

If we have a document of  $N$  total characters and  $M$  unique characters, the number of nodes in the Huffman tree, in complexity notation, is

$$O(M) \tag{53}$$

Clearly, this has nothing to do with  $N$ . Note that we have  $M$  leaf nodes, and in each iteration, we connect 2 nodes up to a parent. Therefore, the number of nodes to connect up decreases by 1 per iteration, and we create a new node per iteration. Since there are  $M - 1$  iterations, we add one node, so there will be  $M + M - 1 = O(n)$  nodes in the binary tree.

## 6 Divide and Conquer

### Definition 6.1 (Divide and Conquer Algorithms)

The general idea is two steps:

1. Divide an input into smaller instances of the same problem. The simplest form is merge sort.
2. Conquer/solve these smaller instances, which takes less time.
3. Merge/Combine the smaller solutions into the original, bigger solution.

This is usually recursive, but does not need to be.

It has its applications in the most elementary operations, in sorting and multiplication. To prove correctness, we use induction by proving the correctness of the base case and then the inductive step to show that there is an invariant.

### 6.1 Recursion and Recurrence

In introductory classes, you would learn about recursive functions.

#### Definition 6.2 (Recursive Function)

A **recursive function** is a function that calls itself one or more times to evaluate.

What you probably may not have learned is that there are two types of recursion—head and tail recursion. Most beginners learn head recursion first.

#### Definition 6.3 (Head Recursion)

**Head recursion** refers to recursive functions that call itself *before* any calculations are done.

The most common example is the factorial and Fibonacci numbers.

#### Example 6.1 (Factorials with Head Recursion)

In order to calculate  $n!$ , we know of the formula  $n! = n \cdot (n-1) \cdot \dots \cdot 2 \cdot 1$ . We can define this recursively with the definition:

$$f(n) = n \cdot f(n-1), \quad f(1) = 1 \tag{54}$$

For example,

$$f(5) = 5 \cdot f(4) \tag{55}$$

$$= 5 \cdot (4 \cdot f(3)) \tag{56}$$

$$= 5 \cdot (4 \cdot (3 \cdot f(2))) \tag{57}$$

$$= 5 \cdot (4 \cdot (3 \cdot (2 \cdot f(1)))) \tag{58}$$

$$= 5 \cdot (4 \cdot (3 \cdot (2 \cdot 1))) \tag{59}$$

$$= 5 \cdot (4 \cdot (3 \cdot 2)) \tag{60}$$

$$= 5 \cdot (4 \cdot 6) \tag{61}$$

$$= 5 \cdot 24 \tag{62}$$

$$= 120 \tag{63}$$

Notice how in head recursion, we must call  $f(n-1)$  before multiplying to evaluate  $f(n)$ . Therefore, head recursion uses lots of memory to build a large intermediate expression (in this case,  $5 \cdot (4 \cdot (3 \cdot (2 \cdot 1)))$ ).

This may not be ideal because in simple cases where we need to compute such numbers, the memory complexity becomes  $O(n)$ .

**Example 6.2 (Fibonacci Numbers with Head Recursion)**

In order to calculate the  $n$ th Fibonacci numbers, we are familiar with the recursive definition

$$f(n) = f(n - 1) + f(n - 2), \quad f(0) = 0, \quad f(1) = 1 \quad (64)$$

For example,

$$f(4) = f(3) + f(2) \quad (65)$$

$$= (f(2) + f(1)) + f(2) \quad (66)$$

$$= ([f(1) + f(0)] + f(1)) + f(2) \quad (67)$$

$$= ([1 + f(0)] + f(1)) + f(2) \quad (68)$$

$$= ([1 + 0] + f(1)) + f(2) \quad (69)$$

$$= (1 + f(1)) + f(2) \quad (70)$$

$$= (1 + 1) + f(2) \quad (71)$$

$$= 2 + f(2) \quad (72)$$

$$= 2 + (f(1) + f(0)) \quad (73)$$

$$= 2 + (1 + f(0)) \quad (74)$$

$$= 2 + (1 + 0) \quad (75)$$

$$= 2 + 1 \quad (76)$$

$$= 3 \quad (77)$$

Again, notice this “triangular shape” of these expression calls.

Tail recursion solves this problem of having large intermediate representations by doing the computations first to evaluate the expression as it is being expanded.

**Definition 6.4 (Tail Recursion)**

**Tail recursion** refers to recursive functions that call itself *after* computations. Most likely, the recursive call must somehow use the computation in its own call, so we would expect the intermediate evaluations to be parameters to the recursive calls.

**Example 6.3 (Factorials with Tail Recursion)**

A tail recursive definition of  $f(n) = n!$  would be as follows:

$$f(n) = g(n, 1), \quad g(n, a) = g(n - 1, a \cdot n), \quad g(1, a) = a \quad (78)$$

where  $a$  is an accumulator. For example,

$$f(5) = g(5, 1) = g(5 - 1, 1 \cdot 5) \quad (79)$$

$$= g(4, 5) \quad (80)$$

$$= g(4 - 1, 5 \cdot 4) \quad (81)$$

$$= g(3, 20) \quad (82)$$

$$= g(3 - 1, 20 \cdot 3) \quad (83)$$

$$= g(2, 60) \quad (84)$$

$$= g(2 - 1, 60 \cdot 2) \quad (85)$$

$$= g(1, 120) \quad (86)$$

$$= 120 \quad (87)$$

Notice how this has the same number of lines (9 lines, with 5 recursive calls and 5 evaluations) as computing  $f(5)$  with head recursion, but this time, we don't have the triangular shape anymore.

#### Example 6.4 (Fibonacci Numbers with Tail Recursion)

A tail recursive definition of  $f(n)$  as the  $n$ th Fibonacci number (index starting from 0) would be as follows:

$$f(n) = g(n, 0, 1), \quad g(n, a, b) = g(n - 1, b, a + b), \quad g(0, a, b) = a \quad (88)$$

For example,

$$f(4) = g(4, 0, 1) = g(4 - 1, 1, 0 + 1) \quad (89)$$

$$= g(3, 1, 1) \quad (90)$$

$$= g(3 - 1, 1, 1 + 1) \quad (91)$$

$$= g(2, 1, 2) \quad (92)$$

$$= g(2 - 1, 2, 1 + 2) \quad (93)$$

$$= g(1, 2, 3) \quad (94)$$

$$= g(1 - 1, 3, 2 + 3) \quad (95)$$

$$= g(0, 3, 5) \quad (96)$$

$$= 3 \quad (97)$$

It seems that the tail recursion behaves like a loop, and indeed, we can prove that the two representations are equivalent.

#### Theorem 6.1 (Equivalence of Tail Recursion and Loops)

Any tail recursive function can be expressed as a loop.

Now to evaluate the runtime of a recursive algorithm, one must implicitly solve for the runtime of its recursive calls, and we can visualize it.

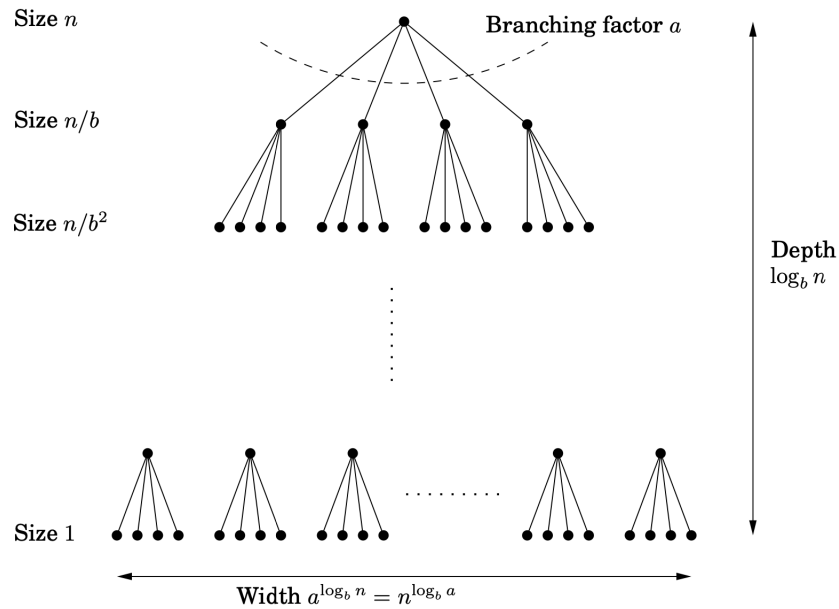

Figure 25

This idea formalizes to the following theorem.

<b>Theorem 6.2 (Master Theorem)</b>	
Given a recurrence relation of form	
$T(N) = aT(N/b) + O(N^c)$	(98)
then the following holds	
$a > b^c \implies T(N) = O(N^{\log_b a})$	(99)
$a = b^c \implies T(N) = O(N^c \log N)$	(100)
$a < b^c \implies T(N) = O(N^c)$	(101)
<p><i>Proof.</i> To intuit this, see that if <math>a &gt; b^c</math>, then there arises a lot of subproblems, so our complexity is greater. If <math>a &lt; b^c</math>, then we have few subproblems and can get a better runtime. If <math>a = b^c</math>, we get somewhere in between. To actually solve this, we can just unravel the recurrence to get the infinite series</p>	
$T(N) = aT(N/b) + O(N^c)$	(102)
$= a^2T(N/b^2) + N^c \left( \frac{a}{b^c} + 1 \right)$	(103)
$= N^c \left( 1 + \frac{a}{b^c} + \frac{a^2}{b^{2c}} + \dots \right)$	(104)
<p>So, if <math>a &lt; b^c</math>, then even as <math>N \rightarrow \infty</math>, the sum is finite, so it is of order <math>O(N^c)</math>. If <math>a = b^c</math>, then the series is just <math>1 + \dots + 1</math>, which scales on the order of <math>O(\log_2 N)</math>. If <math>&gt; 1</math>, then we have to calculate the last term, which contributes to our runtime and overpowers <math>c</math>. Therefore, if <math>a</math> is large, our algorithm will have an exponential number of subproblems and will be bottlenecked.</p>	

## 6.2 Merge Sort and Counting Inversions

### Algorithm 6.0 (Merge Sort)

Merge sort is the first instance.

---

#### Algorithm 4 Merge Sort

---

**Require:** Array nums

```

function MERGESORT(nums)
  n = len(nums)
  if n < 2 then                                     ▷base case
    return nums
  end if
  mid = n // 2
  left_sorted = MergeSort(nums[:mid])                 ▷Divide into left half
  right_sorted = MergeSort(nums[mid:])                 ▷Divide into right half
  res = [0] * n
  i = j = k = 0
  while k < n do                                     ▷Merge the sorted subarrays
    if j == len(right_sorted) or left_sorted[i] < right_sorted[j] then
      res[k] = left_sorted[i]                           ▷We should add the next element from left array
      i += 1                                             ▷if it is smaller or if right array is filled already
    else
      res[k] = right_sorted[j]
      j += 1
    end if
    k += 1
  end while
  return res
end function

```

---

The recurrence relation for the runtime is as follows. Let  $T(n)$  represent the worst-case runtime of MergeSort of size  $n$ . Then, we have

$$T(n) = 2 \cdot T(n/2) + O(n) \quad (105)$$

Consisting of two recursive calls with input size  $n/2$  and then the merge step which is  $O(n)$ . But if we take a look at this, we have

$$T(n) = 2 \cdot T(n/2) + O(n) \quad (106)$$

$$= 2 \cdot (2 \cdot T(n/4) + O(n/2)) + O(n) \quad (107)$$

$$= 4 \cdot T(n/4) + O(n) + O(n) \quad (108)$$

and the number of times  $O(n)$  is added up is  $\log n$ , meaning that this recurrence relation turns into  $O(n \log n)$ .

### Definition 6.5 (Inversions)

Given two lists of ranked items, say

$$\text{Alice : } a > b > c > d > e \quad (109)$$

$$\text{Bob : } b > d > a > e > c \quad (110)$$

We want to measure the dissimilarity between two rankings by counting the number of *inversions*, which are pairs of items for which one person orders the opposite of the other (e.g.  $a, b$  for above).<sup>a</sup> So how many inversions are there? We can do this in  $\Theta(n^2)$  by explicitly looking at all  $n$  pairs. Without loss of generality, we can assume that the first list is sorted simply by bijectively relabeling these elements for both lists. Therefore, the set of inversions is defined to be

$$\{(i, j) \text{ s.t. } i < j \text{ and } A[i] > A[j]\} \quad (111)$$

<sup>a</sup>Also known as Kendall-Tau distance in statistics.

### Algorithm 6.0 (Counting Inversions)

The idea is very similar. By assuming that the first list is sorted, we can simply count the number of inversions in a single list  $A$ .

```
1 A = 5 6 1 3 4 8 2 7
```

1. In the divide step, we count all inversions in  $A_l, A_r$ , which are the left and right sides of  $A$ , and we sort  $A_l, A_r$  to add additional structure.

```
1 1 3 5 6 | 2 4 7 8
```

2. In the conquer step, we merge them linearly but every time we add an element from  $A_r$  into our result, this reveals that there are  $k$  additional inversions added where  $k$  is the number of elements left in  $A_l$  to add.

### Algorithm 5 Counting Inversions

**Require:** Array `nums`

```
function INVERSIONS(nums)
  n = len(nums)
  if n < 2 then
    return nums
  end if
  mid = n // 2
  left_sorted, left_invs = Inversions(nums[:mid])
  right_sorted, right_invs = Inversions(nums[mid:])
  res = [0] * n
  i = j = k = 0
  inv = 0
  while k < n do
    if j == len(right_sorted) or left_sorted[i] < right_sorted[j] then
      res[k] = left_sorted[i]
      invs += len(left_sorted - i)
      i += 1
    else
      res[k] = right_sorted[j]
      j += 1
    end if
    k += 1
  end while
  return res, inv + left_invs + right_invs
end function
```

▷base case  
 ▷Divide into left half  
 ▷Divide into right half  
 ▷left, right, and combined index  
 ▷number of inversions  
 ▷Merge the sorted subarrays  
 ▷We should add the next element from left array  
 ▷Increment inversions by # of elems in left array  
 ▷if it is smaller or if right array is filled already

The recursion relation is still

$$T(n) = 2 \cdot T(n/2) + O(1) + O(n) \implies O(n \log n) \quad (112)$$

### 6.3 Selection and Quick Sort

The next problem is a generalization of finding the median of an array, which we present can be done in  $O(n)$  time *on average*. It turns out that that this idea of choosing a pivot and then dividing and conquering happens often in general selection and sort algorithms.

#### Algorithm 6.0 (Select kth Largest Element from Unsorted Array)

##### Algorithm 6 Find Kth Largest Element

**Require:** Array of numbers `nums`, integer `k` where  $1 \leq k \leq \text{length}(\text{nums})$

```

function FINDKTHLARGEST(nums, k)
  if length(nums) = 1 then                                     ▷Base case: if array has only one element
    return nums[0]
  end if
  pivot ← ⌊length(nums)/2⌋                                     ▷Select middle element as pivot
  left ← []                                                  ▷Unsorted array for elements smaller than pivot
  right ← []                                                 ▷Unsorted array for elements larger than pivot
  n_pivots ← 0                                               ▷Count of elements equal to pivot
  for each n in nums do                                       ▷Start filling in the arrays
    if n = nums[pivot] then
      n_pivots ← n_pivots + 1
    else if n ≤ nums[pivot] then
      left.append(n)
    else
      right.append(n)
    end if
  end for
  if length(right) ≤ k - 1 and length(left) ≤ length(nums) - k then
    return nums[pivot]                                       ▷Found the kth element which was in the middle in n_pivots
  else if length(right) ≥ k then
    return FINDKTHLARGEST(right, k)                         ▷Largest is in the array of bigger numbers.
  else
    return FINDKTHLARGEST(left, k - length(right) - n_pivots)  ▷Largest is in the array of
    smaller numbers.
  end if
end function

```

**Algorithm 6.0 (Quick Sort)****Algorithm 7** Quicksort Algorithm**Require:** Array A of comparable elements

```

function QUICKSORT(A, low, high)
  if low < high then
    p ← PARTITION(A, low, high)           ▷Get pivot position
    QUICKSORT(A, low, p - 1)             ▷Sort left subarray
    QUICKSORT(A, p + 1, high)           ▷Sort right subarray
  end if
end function

function PARTITION(A, low, high)
  pivot ← A[high]                         ▷Choose rightmost element as pivot
  i ← low - 1                             ▷Index of smaller element
  for j ← low to high - 1 do           ▷Scan through array
    if A[j] ≤ pivot then
      i ← i + 1                           ▷Increment index of smaller element
      swap A[i] and A[j]                  ▷Swap current element with pivot
    end if
  end for
  swap A[i + 1] and A[high]               ▷Put pivot in its correct position
  return i + 1                          ▷Return pivot's final
  position
end function

```

**6.4 Closest Pair of Points**

The next problem simply takes a series of points and calculates the closest pair of points. This can be done trivially in  $O(N^2)$  by taking all combinations, but with clever divide and conquer, we can reduce this down. The idea is that we want to divide them into a left and a right side, which we can sort in  $O(N \log N)$  and find the median in  $O(1)$ . This now reduces to computing the closest pair of points in each  $N/2$  half. If we can find the closest pair in each half, then we must compare it to all pairs of points across the halves, meaning that we must do  $(N/2)^2$  comparisons again, leading to

$$T(N) = 2T(N/2) + O(N^2) \quad (113)$$

which isn't any better than  $O(N^2)$ . But imagine that we found that the smallest distance of the left and right were  $\delta_1, \delta_2$ , then for each point in the left side, we don't have to check all  $N/2$  points on the right.

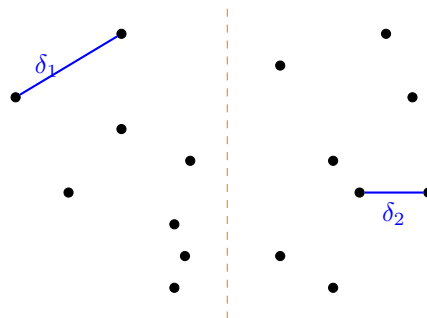
Figure 26: Set of points with two measured distances  $\delta_1$  and  $\delta_2$ .

We just have to check those with distance at most  $\delta = \min\{\delta_1, \delta_2\}$  from each point. Furthermore, we can discard all points that are too far away from the boundary. However, all  $N$  points could like in the relevant space, leading to  $O(N^2)$  computations of distance.

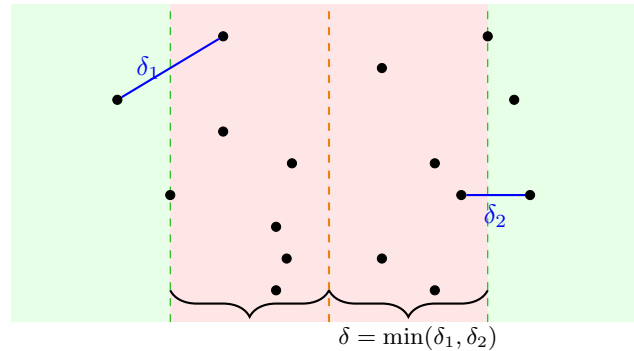

Figure 27: Closest pair algorithm with divide-and-conquer approach: only points within  $\delta$  distance of the dividing line need to be checked for cross-boundary minimum distances. Note that if the closest pair consists of one point being in LHS and the other in the RHS of the red line, then it must lie in between the two green lines.

Therefore, we want to incorporate vertical distances and tile our relevant space into square of side length  $\delta/2$ .

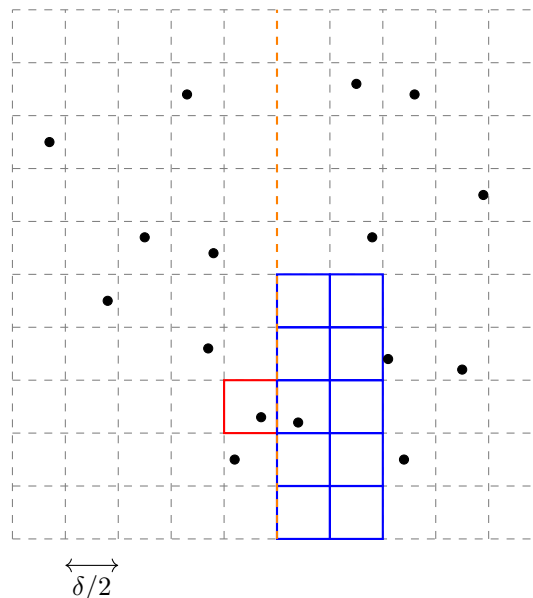

Figure 28: We claim that each square has at most 1 point, since if there were two, then their distance would be less than  $\delta/\sqrt{2}$ , which contradicts the distance between the two points being greater than  $\delta$ . Therefore given a point, we only need to check a bounded constant. The number of points on the other side with distance  $\leq \delta$  is at most 10. If we are more careful, we can reduce the number down to 7.

It turns out that we just need to compute  $5N = (N/2) \cdot 10$  distances at most, and now our question reduces to how do we find these 5 points? Well we can first sort the points on the left and right by their y-coordinates, so we can just take a sliding window that encapsulates these points on the right for every on the left. The pointers of the sliding window should point to a point where the y-coordinate is at most  $\delta$  away, and this can be done in constant time. Therefore, our recurrence relation is

$$T(N) = 2T(N/2) + O(N \log N) \implies T(N) = O(N \log^2 N) \quad (114)$$

This sorting along the  $y$ -coordinates is a bottleneck, but we can just shove this into the recursion step by telling the left and right to not just return the  $\delta_1, \delta_2$ , but also the points sorted in the  $y$ -coordinate. Then at the end of the merge, we also merge the lists  $L, R$  so that  $S = L \cup R$  is sorted on  $y$ , which also takes  $O(N)$  and doesn't add extra runtime on the merge step. This reduces the runtime to  $O(N \log N)$ .

### Algorithm 6.0 (Closest Pair of Points)

The next problem simply takes a series of points and calculates the closest pair of points. This can be done trivially in  $O(N^2)$  by taking all combinations, but with clever divide and conquer, we can reduce this down.

#### Algorithm 8 Closest Pair of Points

**Require:**  $N$  points  $\{(x_i, y_i)\}$ .

```

function CLOSESTPAIR(P)
  Sort points by x-coordinate. ▷Bottleneck of  $O(N \log N)$ 
  if len(P) = 2 then
    return  $d(p_1, p_2)$ , sorted  $P$  by y-coord
  end if
   $\delta_1, L \leftarrow$  ClosestPair( $P_L$ )
   $\delta_2, R \leftarrow$  ClosestPair( $P_R$ )
   $\delta = \min\{\delta_1, \delta_2\}$ 
   $\min \leftarrow \delta$ 
  for  $l \in L$  s.t. distance to boundary  $\leq \delta$  do ▷ $O(N)$  iterations
     $W_l \leftarrow$   $\delta$ -window of points in  $R$  around  $l$ . ▷Can be done in  $O(1)$  using sliding window.
    for  $r \in W_l$  do ▷This is bounded by  $O(10)$ 
      if  $d(p, l) < \delta$  then
         $\min \leftarrow d(p, l)$ 
      end if
    end for
  end for
  merge  $L$  and  $R$  into sorted  $S$  ▷ $O(N)$ 
  return  $\min, S$ 
end function

```

## 6.5 Multiplication

### 6.5.1 Karatsuba Algorithm

### 6.5.2 Strassen Algorithm

We can solve matrix multiplication of two  $N \times N$  matrices in a slightly more clever way than  $O(N^3)$ . Note that we can take the  $2 \times 2$  block form of matrices  $A, B$  and multiply them to get  $C = AB$ , where

$$C_{11} = A_{11}B_{11} + A_{12}B_{21} \quad (115)$$

$$C_{12} = A_{11}B_{12} + A_{12}B_{22} \quad (116)$$

$$C_{21} = A_{21}B_{11} + A_{22}B_{21} \quad (117)$$

$$C_{22} = A_{21}B_{12} + A_{22}B_{22} \quad (118)$$

This requires us to compute a total of 8  $N/2 \times N/2$  multiplications and 4 additions, each of which is  $O(N^2)$ .

Therefore, our recurrence relation is

$$T(N) = 8T(N/2) + O(N^2) \quad (119)$$

Using the master theorem, we find that  $a = 8 > 2^2 = b^c$ , so our runtime is  $O(N^{\log_b a}) = O(N^3)$ , which brings us right back to where we started. The problem with this is that  $a = 8$ , which is large. If we could get  $a = 7$ , then this would be an improvement. We want to reduce this number of multiplications, and we can do this using the Strassen algorithm, which uses the following values.

$$P_1 = (a_{11} + a_{22})(b_{11} + b_{22})$$

$$P_2 = (a_{21} + a_{22})b_{11}$$

$$P_3 = a_{11}(b_{12} - b_{22})$$

$$P_4 = a_{22}(b_{21} - b_{11})$$

$$P_5 = (a_{11} + a_{12})b_{22}$$

$$P_6 = (a_{21} - a_{11})(b_{11} + b_{12})$$

$$P_7 = (a_{12} - a_{22})(b_{21} + b_{22})$$

Then, we claim that the entries of  $C$  are

$$c_{11} = P_1 + P_4 - P_5 + P_7$$

$$c_{12} = P_3 + P_5$$

$$c_{21} = P_2 + P_4$$

$$c_{22} = P_1 + P_3 - P_2 + P_6$$

So we have reduced 8, 4 mult/add to 7, 18 mult/add. Addition is cheap and the number of additions is bounded, so now we have decreased  $a$  to 7.<sup>7</sup> We can then solve the new recurrence relation

$$T(N) = 7T(N/2) + O(N^2) \implies O(N^{\log_2 7}) \approx O(N^{2.81}) \quad (120)$$

## 6.6 Polynomial Multiplication with Fast Fourier Transform

Given as inputs 2 degree  $N$  polynomials,

$$A(x) = a_0 + a_1x + a_2x^2 + \dots + a_{n-1}x^{n-1} \quad (121)$$

$$B(x) = b_0 + b_1x + b_2x^2 + \dots + b_{n-1}x^{n-1} \quad (122)$$

we want to multiply them to  $C(x) = A(x)B(x)$  defined

$$C(x) = c_0 + c_1x + \dots + c_{2n-2}x^{2n-2} \quad (123)$$

Clearly, we must multiply every coefficient in  $A$  with  $B$ , which takes  $O(N^2)$  time. It is also called the convolution operation.

Convolution of  $(a_0, a_1, \dots, a_{n-1})$  and  $(b_0, b_1, \dots, b_{n-1})$

$$c_0 = a_0b_0$$

$$c_1 = a_0b_1 + a_1b_0$$

$$c_2 = a_0b_2 + a_1b_1 + a_2b_0$$

$$c_3 = a_0b_3 + a_1b_2 + a_2b_1 + a_3b_0$$

$\vdots$

$$c_{2n-2} = a_{n-1}b_{n-1}$$

We can actually compute this convolution of two vectors in  $O(N \log N)$  time using the FFT algorithm. Let's ease into this idea.

<sup>7</sup>We can reduce it even further, down to 2.37. Whether  $O(N^2)$  is possible is an open problem.

**Lemma 6.3 (Evaluating a Polynomial at  $x$ )**

If we are given an  $x$  and want to evaluate  $A(x)$ , we can just incrementally evaluate the terms up each degree in  $O(N)$  time.

**Algorithm 9** Evaluate polynomial  $A(x)$  at  $x = p$ 

```

1:  $S \leftarrow a_0$ 
2:  $R \leftarrow x$ 
3: for  $i = 1, 2, \dots, n - 1$  do
4:    $S \leftarrow S + a_i \cdot R$ 
5:    $R \leftarrow R \cdot x$ 
6: end for

```

Great, we can make some progress, but what does this have to do with finding the actual polynomial? Recall that from the fundamental theorem of algebra, a set of  $n + 1$  points will uniquely determine a  $n$ th degree polynomial. This at first glance doesn't help, since evaluating all  $n + 1$  points is  $O(n^2)$ , and even if we did, this doesn't really tell us how to reconstruct the polynomial in some fast time (e.g. matrix inversion won't work). But note that if we have a 1st degree polynomial, then evaluating it at  $\pm 1$  will retrieve the whole polynomial back

$$f(x) = a_0 + a_1x \implies \begin{cases} f(+1) = a_0 + a_1 \\ f(-1) = a_0 - a_1 \end{cases} \implies \begin{cases} a_0 = \frac{1}{2}(f(+1) + f(-1)) \\ a_1 = \frac{1}{2}(f(+1) - f(-1)) \end{cases} \quad (124)$$

We can think of this as sort of our base case. For  $N$ th degree polynomials, we can divide it into a even and odd powers part.

$$A(x) = a_0 + a_1x + a_2x^2 + \dots \quad (125)$$

$$= (a_0 + a_2x^2 + a_4x^4 + \dots) + x(a_1 + a_3x^2 + a_5x^4 + \dots) \quad (126)$$

$$= A_{\text{even}}(x^2) + xA_{\text{odd}}(x^2) \quad (127)$$

where each of the splits have degree  $N/2$ . Then we want to evaluate the even and odd parts.

Let's jump ahead and focus on the problem of evaluating  $A(x)$  of degree  $N$  at the  $N$ th roots of unity.

**Example 6.5**

For  $N = 4$ , we evaluate at  $\pm 1, \pm i$ .

$$A(x) = (a_0 + a_2x^2) + x(a_1 + a_3x^2) \quad (128)$$

which gives us

$$A(+1) = A_e(+1) + A_o(+1) \quad (129)$$

$$A(-1) = A_e(+1) - A_o(+1) \quad (130)$$

$$A(+i) = A_e(-1) + iA_o(-1) \quad (131)$$

$$A(-i) = A_e(-1) - iA_o(-1) \quad (132)$$

Note that even though we had  $\pm i$  evaluated on  $A$ , they were all squared in each split so evaluating the 4th of unity, which we denote  $U(4)$ , has been reduced to finding  $U(2)$  for each of the left and right polynomials.

Therefore, to evaluate  $A$  of degree  $N$  at  $U(N)$ , it suffices to evaluate  $A_e, A_o$  each at  $U(N/2)$ , followed by

combing them using addition and multiplication, which turns out to be  $O(N)$ . Therefore, for each step of evaluating  $A$ , you

1. evaluate  $A_e$  and  $A_o$ , and
2. then combine them in  $\Theta(N)$  time

Algorithm 6.0 (Evaluate Nth Degree Polynomial at Nth Roots of Unity)
<hr style="border: none; border-top: 1px solid black; margin-bottom: 10px;"/> <p><b>Require:</b></p> <pre style="margin: 0;"> <b>function</b> FUNC(x)   <b>end function</b> </pre> <hr style="border: none; border-top: 1px solid black; margin-top: 10px;"/>

Therefore, we have divided the problem of evaluating over  $U(N)$  to be

$$T(N) = 2T(N/2) + O(N) \implies T(N) = O(N \log N) \quad (133)$$

So we have shown that in general, evaluating  $N$  points of a polynomial takes  $O(N^2)$  time, but if you're clever about what points to evaluate, you can get  $O(N \log N)$ .

Now going back to the original problem, we can evaluate  $A(u), B(u)$  for  $u \in U(N)$ , and then multiply them to get  $C(u)$ . Great. Now to reconstruct the polynomial using the roots of unity, it turns out that there is a method in  $O(N \log N)$  time as well.

## 7 Graph Algorithms

### 7.1 Directed Acyclic Graphs and Topological Sorting

Now we move onto a specific type of directed graphs that are *acyclic*. Let's introduce what they are first.

#### Definition 7.1 (Directed Acyclic Graph)

A DAG is a directed graph that has no cycles. Note that a DAG must have a node that has no in-edges.

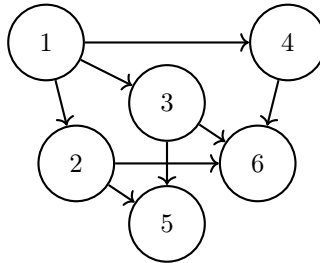

Figure 29: An example of a directed acyclic graph.

To determine if a graph is a DAG, then we can brute force it by taking a node  $s \in V$ , running DFS/BFS, and if a neighbor is already in visited, return False. Then go through this for all starting nodes  $s \in V$ . This again has quadratic runtime. Can we do better? This introduces us to topological<sup>8</sup> sorting.

It may be helpful to take a graph  $G(V, E)$  and induce some partial order on the set of nodes  $V$  based off of  $E$ . It turns out that we can do this for a specific type of graph.

#### Definition 7.2 (Topological Sort)

Given a directed acyclic graph (DAG), a linear ordering of vertices such that for every directed edge  $u - v$ , vertex  $u$  comes before  $v$  in the ordering is called a **topological sort**. It satisfies the facts:

1. The first vertex must have an in-degree of 0.
2. A topological sort is not unique.

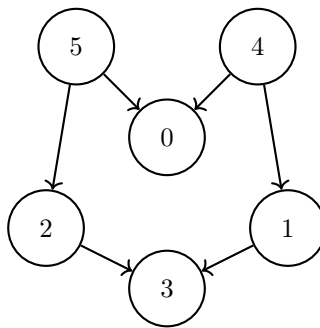

Figure 30: This graph can have the two (not exhaustive) topological sortings  $[5, 4, 2, 3, 1, 0]$  and  $[4, 5, 2, 3, 1, 0]$ .

To determine if a graph is a DAG, note the following theorem.

<sup>8</sup>This has nothing to do with topology in mathematics, but rather the etymology came from the word “topology” in describing the structure of networks.

**Theorem 7.1 (Topological Order and DAGs)**

$G$  has a topological order if and only if it is a DAG.

*Proof.* To prove that a DAG has a topological order, we use induction. Pick a  $v$  such that its indegree is 0. Then, delete  $v$ , and therefore  $G \setminus v$  is also a DAG with a topological order since we are only deleting edges. We keep going.

Therefore, if we can successfully topologically sort, we know it is a DAG. So we can kill two birds with one stone. Let's see how this is implemented. We can do it iteratively and recursively (the proof above should hint that this can be recursive).

**Algorithm 7.0 (Iterative Topological Sort, Determine If Graph is DAG)**

The general idea is that we first find the node that has 0 in-degree. From here, we can do DFS, and when we run out of neighbors to explore, then we push this into a queue. This is essentially a post-order traversal, where at the end are going to be the end nodes with no more neighbors, and the node we started from will be added last. Then we loop through and do this for all start nodes. We first need a slightly modified form of DFS.

---

**Require:** Nodes  $V$ , adjacency list  $E$

```

1: visited ← set()
2: res ← stack()
3: is_acyclic ← True
4: function DFS( $v \in V$ )
5:   if  $v \neq$  visited then
6:     add  $v$  to visited
7:      $N_v \leftarrow$  neighbors of  $v$ 
8:     for  $n \in N_v$  do
9:       if  $n \in$  visited then
10:        is_acyclic ← False
11:      end if
12:      DFS( $n$ )
13:    end for
14:    push  $v$  onto res
15:  end if
16: end function
17:
18: function TOPOLOGICALSORT( $V, E$ )
19:  for  $v \in V$  do
20:    DFS( $v$ )
21:  end for
22:  if ! is_acyclic then
23:    return False
24:  end if
25:  return reversed of res
26: end function

```

---

Note that this runtime is  $O(|V| + |E|)$  since we are just running DFS with a constant amount of work on top of each call.

**Algorithm 7.0 (Recursive Topological Sort)**

We want to see that while  $G$  is nonempty, we want to find the  $v \in V$  such that it has indegree 0. Then place  $v$  next in order, and then delete  $v$  and all edges out of  $v$ . The problem is finding which vertex has indegree 0 (if we brute force it by looking through all remaining nodes and edges, you have quadratic runtime). To do this fast, the idea is

1. initially scan over all edges to store the indegrees of every node to a list `indeg`.
2. store all nodes with indegree 0 to a queue.
3. Run through the queue, and during each loop, when we remove a node, we look at all of its out-nodes  $s$  and decrement `indeg[s]`. If `indeg[s] = 0`, then add it to the queue.

---

**Require:** Nodes  $V$ , Edges  $E$

```

1:  $q \leftarrow \text{queue}()$ 
2:  $\text{indeg} \leftarrow \text{list}()$ 
3:  $\text{visited} \leftarrow 0$ 
4: function RECUR( $x$ )
5:   initialize the  $\text{indeg}$  and  $q$ 
6:   while  $q$  is nonempty do
7:      $v \leftarrow \text{pop}(q)$ 
8:      $\text{visited} += 1$ 
9:     for each  $w \in E[v]$  do
10:       $\text{indeg}[w] -= 1$ 
11:      if  $\text{indeg}[w] = 0$  then
12:        push  $w$  into  $q$ 
13:      end if
14:    end for
15:  end while
16:  if  $\text{visited} \neq |V|$  then
17:    return False
18:  end if
19:  return True
20: end function

```

---

Notice that the inner for loop is  $O(d(v) + 1)$ , while we run over all  $n$ . So really, we are doing  $O(n(d(v) + 1)) = O(m + n)$ , where the plus  $n$  comes from the constant work we are doing for each node. Note that if we have a non-DAG, then at some point the queue will be empty but we haven't processed all the vertices, at which point we can declare failure.

To end this, we can make a general statement about all directed graphs.

**Theorem 7.2**

Every directed graph is a DAG of strongly connected components (SCC).

This gives us a way to represent a directed graph with a collection of DAGs.<sup>9</sup> An extension of topological sort is making a *BFS tree*, which partitions a graph into layers that represent the number of steps required to go from a source vertex to a node.

---

<sup>9</sup>In fact, this Kosaraju's algorithm, can be done in linear time, though it is highly nontrivial.

**Algorithm 7.0 (BFS Tree)**

To construct a BFS tree, we just need to slightly modify the original BFS code.

---

**Require:** Nodes  $V$ , adjacency list  $E$

```

1: visited = set()
2: layers = {v : 0 | v ∈ V}
3: function BFS(start)
4:   layer ← 0
5:   toExplore ← queue()
6:   add (start, layer) to toExplore
7:   add start to visited
8:   while toExplore do
9:     curr, layer = pop from toExplore
10:    layers[curr] = layer
11:    for n ∈ neighbors of curr do
12:      if n ∉ visited then
13:        add n to visited
14:        add (n, layer + 1) to visited
15:      end if
16:    end for
17:  end while
18: end function

```

---

This is simply BFS with constant extra work so it is  $O(n + m)$ .

So, a BFS tree is really just another way to topologically sort. Note the following properties.

1. In a directed graph, no nodes can jump from layer  $i$  to layers  $j > i + 1$ , since if it could, then it would be in layer  $i + 1$ . However, nodes can jump from layer  $j$  back to any layer  $i < j$ , even skipping layers.
2. In a directed graph, going forward is the same as going back, so nodes can jump at most one layer forwards or backwards.

## 7.2 Bipartite Graphs

Now we shall see a further application of BFS trees.

**Definition 7.3 (Bipartite Graph)**

A **bipartite graph** is an undirected graph  $G(V, E)$  where we can partition  $V = L \sqcup R$  such that for all  $e = \{u, v\} \in E$ , we have  $u \in L, v \in R$ .

We would like to devise some method to determine if an arbitrary graph is bipartite.

**Theorem 7.3**

$G$  is bipartite if and only if all cycles in  $G$  are even length.

*Proof.* Proving ( $\implies$ ) is quite easy since if we suppose  $G$  has an odd length cycle, then we start packing vertices of a cycle into  $L, R$ , but by the time we came back to the start, we are forced to pack it into the wrong partition!

The converse is quite hard to prove, and we'll take it at face value.

Now in practice, how would we determine if all cycles are even length? This is where BFS shines.

#### Algorithm 7.0 (Determine Bipartite On All Cycles of Even Length)

The general idea is we first run BFS on the graph starting at  $s \in V$ , which divides it up into layers  $L_1, \dots, L_l$  representing the shortest path from  $s$ . Then for each layer  $L_i \subset V$ , we check if there are connections between two vertices  $x, y \in L_i$ . If there are connections, then this is not bipartite. If there are none, then this is bipartite since we can then color it.

**Require:** Nodes  $V$ , adjacency list  $E$

```

1: visited = set()
2: layers = {v : 0 | v ∈ V}
3: function BFS(start)
4:   layer ← 0
5:   toExplore ← queue()
6:   add (start, layer) to toExplore
7:   add start to visited
8:   while toExplore do
9:     curr, layer = pop from toExplore
10:    layers[curr] = layer
11:    for n ∈ neighbors of curr do
12:      if n ∉ visited then
13:        add n to visited
14:        add (n, layer + 1) to visited
15:      end if
16:    end for
17:  end while
18: end function
19:
20: function BIPARTITE(V, E)
21:   BFS(v) for some v ∈ V
22:   for (u, v) ∈ E do
23:     if layers[u] == layers[v] then
24:       return False
25:     end if
26:   end for
27:   return True
28: end function

```

Therefore, we run BFS, which is  $O(n + m)$ , and then to compare the edges, it is  $O(m)$ .

Bipartiteness is actually a special case of *coloring problems*. Given a graph with  $k$  colors, can I color it so that every neighbor has a different color than the original node? It may seem like at first glance that we can do the same method and look at the layers again, but it turns out that 3-coloring is hard. More specifically it is an NP-complete problem, which colloquially means that there isn't much of a better way than a brute-force solution. However, it turns out that according to the *4 color theorem*, any map can be colored with 4 colors.

### 7.3 Strongly Connected Graphs

Now how do we find out if a directed graph is strongly connected? The straightforward solution would be to take each vertex  $v \in V$ , run BFS to find the set of vertices reachable from  $v$ , and do this for every vertex. The total running time is  $O(n(n+m))$ , which is quadratic. Note that for an undirected graph this is trivial since we just run DFS/BFS once.

#### Definition 7.4 (Strongly Connected Graph)

A graph  $G$  is **strongly connected** if and only if for any  $v \in V$ ,

1. all of  $V$  is reachable from  $v$ .
2.  $v$  is reachable from any  $s \in V$

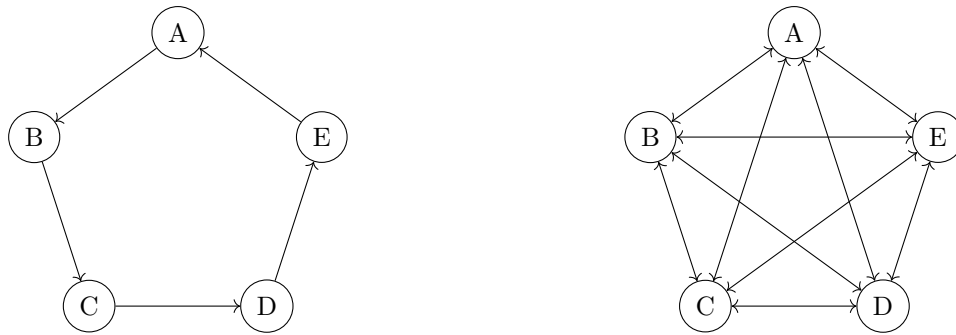

Figure 31: Two examples of strongly connected components.

#### Algorithm 7.0 (Determine if Graph is Strongly Connected)

Using the theorem above, we can run BFS/DFS twice: one on the original graph and one on the reversed graph, consisting of all edges directed in the opposite direction.

---

**Require:** Nodes  $V$ , Adjacency list  $E$

- 1: **function** STRONGLYCONNECTED( $s \in V$ )
- 2:   visited  $\leftarrow$  set()
- 3:   BFS( $s$ )
- 4:   **if** visited  $\neq V$  **then**
- 5:     **return** False
- 6:   **end if**
- 7:   visited  $\leftarrow$  set()
- 8:   reverse all edges in  $E$
- 9:   BFS( $s$ )
- 10:   **if** visited  $\neq V$  **then**
- 11:     **return** False
- 12:   **end if**
- 13:   **return** True
- 14: **end function**

---

The running time is just running BFS twice plus the time to reverse the edges, so it is  $O(n+m)$ .

One way to decompose an arbitrary graph is into its strongly connected *component graphs*. Since we know that all nodes in a *strongly connected component (SCC)* is reachable from each other, we can treat each component as a node in a *condensation graph*.

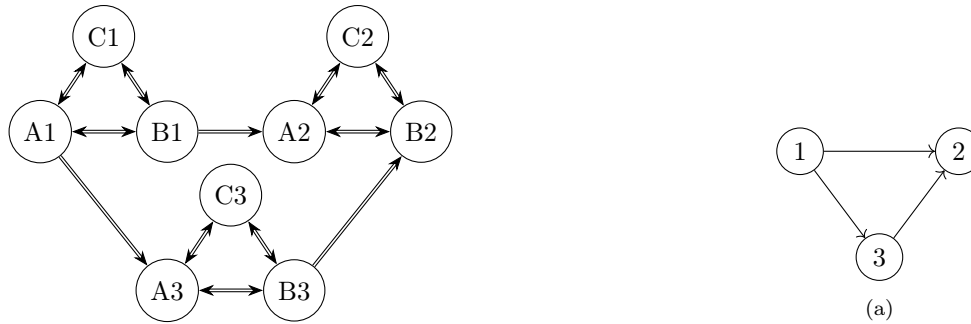

Figure 32: A graph with 3 strongly connected components, along with its condensation graph.

**Algorithm 7.0 (Kosaraju's SCC Algorithm)**

Kosaraju's algorithm finds strongly connected components (SCCs) in a directed graph. An SCC is a maximal subgraph where every vertex is reachable from every other vertex. The algorithm works in two phases: Perform DFS on original graph to get finishing order of vertices. Perform DFS on transposed graph in reverse order of finishing times.

**Algorithm 10** Kosaraju's Algorithm for Strongly Connected Components

```

1: procedure KOSARAJU( $G(V, E)$ )
Require: A directed graph  $G$  with vertices  $V$  and edges  $E$ 
Ensure: A list of strongly connected components in  $G$ 
2:    $L \leftarrow$  empty list                                ▷To store vertices in order of finish time
3:    $visited \leftarrow$  set of all vertices initialized to false    ▷Track visited status for first DFS
4:   for all  $v \in V$  do                                    ▷First DFS pass to get finishing order
5:     if  $visited[v] = \text{false}$  then                    ▷Only start DFS from unvisited vertices
6:       Perform DFS from  $v$  in  $G$ , mark vertices as visited, and add each vertex to the beginning
of  $L$  after its exploration is complete    ▷First DFS builds vertex ordering based on finish times
7:     end if
8:   end for
9:    $G^T \leftarrow$  transpose of  $G$                         ▷Create a new graph with all edges reversed
10:   $visited \leftarrow$  set of all vertices initialized to false    ▷Reset for second DFS
11:   $SCC \leftarrow$  empty list                                ▷Final result: list of SCC groups
12:  for all  $v \in L$  in order do    ▷Process vertices by decreasing finish time (L is already in reverse
finish order)
13:    if  $visited[v] = \text{false}$  then                    ▷Each unvisited vertex starts a new SCC
14:       $component \leftarrow$  empty list                ▷To collect vertices in current SCC
15:      Perform DFS from  $v$  in  $G^T$ , mark vertices as visited, and add each visited vertex to
 $component$                                 ▷Second DFS identifies all vertices in current SCC
16:      add  $component$  to  $SCC$                             ▷Store the identified component
17:    end if
18:  end for
19:  return  $SCC$                                         ▷Return all strongly connected components
20: end procedure

```

## 7.4 Shortest Positive Path with Dijkstra's

In the shortest path, you are given a *weighted* (positive integer) directed graph and your goal is to find a path from  $s$  to  $t$  with the smallest length. So how would we do this?

The first brute force idea is just replace a edge with length  $k$  to  $k$  edges of length 1, and we run BFS on this.

However, this has two disadvantages. First, we cannot do this for non-discrete weights since there may be no way to discretize the weights (but if they were integers, we can take the gcd of all edge weights and use this). Second, it may not be efficient since the weights can be unbounded, and so you may end up splitting 1 edge into 1 million edges. However, if we know that the weights are bounded (and discrete) by a factor of  $K$ , we can use this method to run in  $O(K(M + N)) = O(M + N)$ .

The second is a greedy approach, where we explore as if we were doing BFS, but we greedily choose which edge to explore next by taking the minimum weight in our queue. We can simply do a linear scan to find the minimum, but this may be too slow, leading to quadratic runtime. However, we can use a priority queue (e.g. a min-heap), and so by replacing the queue in BFS with a priority queue (with minimum weights popped off first), we can *Dijkstra's algorithm*.

Note that the expensive operation is to push and pop from the heap, and so we would like to minimize this. Therefore, whenever we find a new candidate, we can check with the current shortest distances and not have to push at all if the current path to node  $X$  is longer than the already recorded shortest path to  $X$ .

### Algorithm 7.0 (Dijkstra's Algorithm)

The general idea is to run a graph traversal like BFS but when you reach a new vertex  $v$ , you can store the accumulated time it took to get to  $v$  and store for all neighbors the accumulated time it will take to get to each of those neighbors. If it is less than what we have currently, then we have found a shorter path and we should update this.

**Require:** Nodes  $V$ , Edges  $E$

```

1: function DIJKSTRA( $s$ )
2:    $dist \leftarrow$  list of size  $|V|$  with  $+\infty$       ▷Initialize list of big nums representing shortest distances
3:    $dist[s] \leftarrow 0$                                ▷The starting node has dist 0
4:    $predecessors \leftarrow \{v : None \mid v \in V\}$       ▷predecessors of each node for path tracking
5:    $toExplore \leftarrow$  minheap()                    ▷A priority queue of (weight, node)
6:   add  $(0, s)$  to  $toExplore$                           ▷You want to explore this first
7:   while  $toExplore$  do
8:      $(curr\_dist, curr\_node) \leftarrow$  pop from  $toExplore$       ▷pop from toExplore
9:     if  $curr\_dist > dist[curr\_node]$  then                ▷If this distance is greater than what
10:      continue                                           ▷I already have then not worth exploring
11:    end if
12:    for  $neighbor, weight \in E[curr\_node]$  do              ▷Look at each neighbor
13:       $new\_dist \leftarrow curr\_dist + weight$           ▷The distance to getting to neighbor from now
14:      if  $new\_dist < dist[neighbor]$  then                ▷If this new dist is shorter than what we have
15:         $dist[neighbor] = new\_dist$                        ▷Update best distance
16:         $predecessors[neighbor] = curr\_node$              ▷Update its predecessor
17:        push  $(new\_dist, neighbor)$  onto  $toExplore$       ▷Should prob explore from here
18:      end if
19:    end for
20:  end while
21:  return  $distances, predecessors$ 
22: end function

```

You essentially push  $n$  times and pop  $m$  times, and the time per push and pop is  $\log_2(n)$ . Therefore, the total time to push is  $n \log(n)$  and to pop is  $m \log(n)$ , making the total runtime  $O(\log(n)(n + m))$ .

**Example 7.1 (Dijkstra's Walkthrough)**

Let's conduct Dijkstra's on the following graph. We set our `dist` list to contain the shortest discovered paths  $[+\infty, +\infty, +\infty, +\infty]$  and initialize our priority queue (min-heap) with our starting node  $\langle(0, A)\rangle$ .

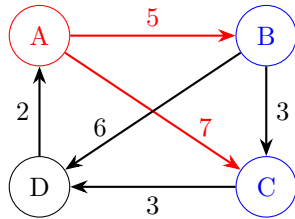

(a) You first pop  $A$  from priority queue and have current weight 0. You see that you can explore  $B$  with weight 5 and  $C$  with weight 7, so you immediately update the shortest paths to  $B$  and  $C$  and visually mark the edges as visited. You then add the nodes to your minheap, which is  $\langle(7, C), (5, B)\rangle$ . Our shortest path for the start node is updated to  $[0, 5, 7, +\infty]$ .

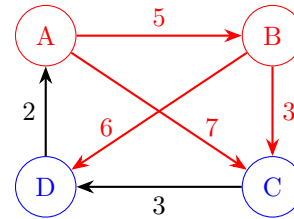

(b) You pop  $B$  off the priority queue and have current weight 5. You see that you can explore  $C$  with weight 3, so total weight  $3+5=8$ , but this is already longer than the recorded shortest path of 7, so skip this. You also see that you can explore  $D$  with weight 4, so total weight  $4+5=9$ . You add  $(11, D)$  to your priority queue:  $\langle(11, D), (7, C)\rangle$ .  $[0, 5, 7, 11]$ .

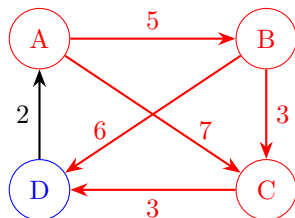

(c) You pop  $C$  off the priority queue with weight 7. You can explore  $D$  with weight 3, so total weight  $3+7=10$ . You add  $(10, D)$  to the priority queue and update the shortest distance.  $\langle(11, D), (10, D)\rangle$ . You can alternatively use the decrease-key operation of a min-heap to directly modify  $(11, D)$  to  $(10, D)$  in  $\log(n)$  time to get  $\langle(10, D)\rangle$ . Note that both requires  $2\log(n)$  operations  $[0, 5, 7, 10]$ .

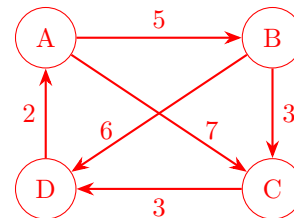

(d) Assuming you haven't used decrease-key, you pop  $D$  off the priority queue with current weight 10.  $\langle(11, D)\rangle$  and  $[0, 5, 7, 10]$ . You can reach  $A$  from  $D$ , but it has a weight of 2 for a total weight of 12, which is greater than 0, so skip this. If you have not used the decrease-key operation, you must pop off  $D$  once more with current weight of 11, but this is already larger than 10, so skip this. the priority queue is empty and our shortest distances is finished.

Figure 33: Walkthrough of Dijkstra on a small graph. Red represents the nodes/edges you have explored, and blue represents the ones in your priority queue.

Note that the decrease-key operation is needed to ensure that we only push and pop off exactly once. Otherwise we may have a long line of unnecessary pushes for a single node, especially if  $D$  has in-edges from every other node.

Note that the number of pushes and pops in the heap can change depending on the order in which you check. In general, updating the shortest path list as you push onto the heap (rather than when you pop off the heap) allows you to save the most computation. However, whether we use the decrease-key operation or push/pop the same node another time from the heap does not affect the fact that we have an extra  $\log(n)$  operation. However, if we use a heap with  $d$  children, we can modify the runtime to  $d\log_d(n)$ . Therefore, the total runtime with tunable parameter  $d$  is

$$O((m + nd) \log_d(n)) \quad (134)$$

which can be minimized if we set  $d = m/n$ , so  $O(m \log_{m/n} n)$ , where for dense graphs  $m/n$  is large and so it can behave roughly in linear time  $\Theta(m)$ .

## 7.5 Negative Weighted Graphs with Bellman Ford

Now let's extend this problem to find the shortest path in negative weighted graphs. Before we think of a solution, we must make sure that there is no cycle that has a negative accumulated path. Otherwise, this problem becomes ill-defined, so we first assume that such a shortest path exists.

This seems like a very similar problem to Dijkstra, but it turns out that in many computer science problems—including this one—a slight modification to a problem can drastically affect the best method to solve it, or even if it is efficiently solvable at all. Let's try to just run Dijkstra, but we can construct a counterexample where this wouldn't work.

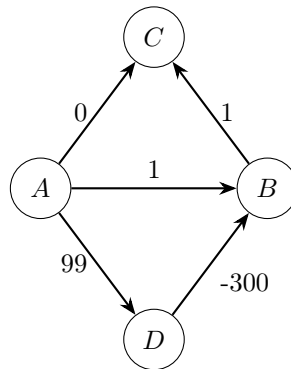

Figure 34: When you pop off the starting node  $A$ , we have  $[0, 1, 0, 99]$ . Then you expand out node  $C$ , which has no changes since there's no outgoing nodes. Then you expand out node  $B$ , which has no effect. Then you expand out  $D$ , which changes  $[0, -299, 0, 99]$ . However, the shortest path to  $C$  is  $A \rightarrow D \rightarrow B \rightarrow C$  of weight  $-200$ .

We can see that for Dijkstra, its greedy nature doesn't allow it to forsee far into the future. Somewhere along a path where Dijkstra may not think is shortest, may exist an edge with a very negative weight that just kills your accumulator. Therefore, a greedy solution may not work.

These pesky negative weights are the root of this problem, so we may think of adding  $\min(v)$ , the minimum weight to every edge so that this now just becomes a regular positive graph and run Dijkstra on it. However, this does not work since we are not adding a constant number over all paths (it is proportional to the number of nodes in the path).

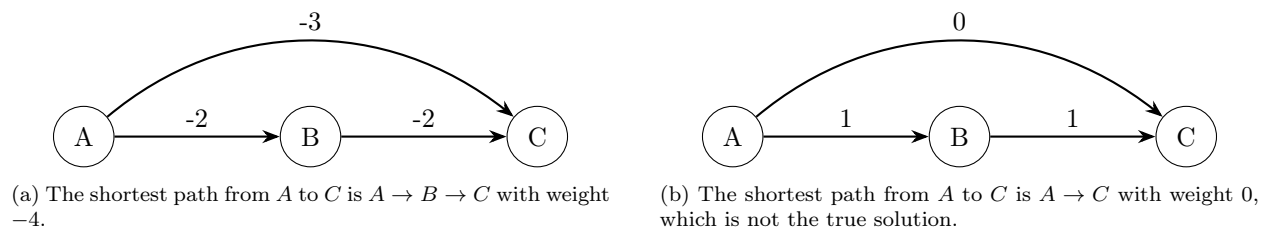

Figure 35: Shortest negative paths may not be the same after adding constants to every edge, since paths of different lengths get different added weights.

So it's pretty clear that we can't use Dijkstra, and we must develop a completely new way. In fact, there is a 50-year conjecture that this cannot be improved to linear time. To develop our new method, we can use the Bellman equations.

**Theorem 7.4 (Bellman Equations)**

We write the **Bellman equations**.

$$d[v] = \min_w \{d[w] + l_{wv}\} \quad (135)$$

with  $d[s] = 0$  for the starting vertex. The solution has a unique solution that finds the shortest path from  $s$  to any  $v \in V$ .

*Proof.* Note that  $d[w] + l_{wv}$  is the length from some path from  $s \mapsto v$  that goes through  $w$ . The minimum of it must be the shortest path over all  $w \in V$ . Suppose the shortest path goes through fixed  $x$ . If there exists a shorter path from  $s \mapsto x$ , then replace  $d[x]$  by this shortest path. Therefore,

$$d[v] = d[x] + l_{xv} \leq d[w] + l_{wv} \implies d[v] = \min_w \{d[w] + l_{wv}\} \quad (136)$$

To prove uniqueness, suppose there are some other solutions  $\pi$  where  $\pi[v] \neq d[v]$  for some  $v$ . But this cannot be the case by definition since  $d[v] \leq \pi[v]$  for all  $v$ .

**Theorem 7.5**

Given the shortest paths, we can lay out this graph like a tree where  $l_{ab} = l_{aa_1} + l_{a_1a_2} + \dots + l_{a_nb}$ .

To implement this theory, we should think of an iterative update that checks for all paths that may be of length  $N - 1$  (since length  $N$  paths are guaranteed to be cycles).

**Algorithm 7.0 (Bellman Ford)**

The general idea is that we want to keep a list of the shortest paths to each node, and we iterate through the whole graph  $N - 1$  times. Within each iteration, we loop through all of the nodes, look at each node's outgoing edges, and try to update the minimum distance to each path. Therefore, by the end of the  $i$ th iteration, we can find all shortest paths up to length  $i$ , which is why by the end of the  $N - 1$  iteration, we will have seen all the non-cycle paths.

---

**Require:** Nodes  $V$ , Edges  $E$

```

1: function SHORTPATH( $V, E$ )
2:    $res \leftarrow$  list(0) of large numbers of size  $|V|$ .
3:    $res[s] = 0$ 
4:    $predecessors \leftarrow \{v : None | v \in V\}$ 
5:   while  $\exists(u, v)$  s.t.  $res[v] > res[u] + l_{uv}$  do
6:      $res[v] \leftarrow res[u] + l_{uv}$ 
7:      $predecessor[v] \leftarrow u$ 
8:   end while
9: end function

```

---

This is guaranteed to converge and stop after a finite number of steps since at every iteration, a path will either

1. get updated from infinity to a path length
2. get reduced from a path length to a shorter path length

And we will have to reach the shortest path length at which point we can't reduce it further.<sup>a</sup>

Computing the runtime is a bit tricky, since we can look at the same edge twice since minimum paths may have been updated in the middle. Therefore this list  $res$  may reduce very slowly. For example,

let the length of each edge  $|l_e| \leq L$ . Then in the worst case,  $\text{res}[s]$  can be initialized to  $(n-1)L$  representing the max path across all nodes, and we can decrease by 1 in each step. So over all nodes, we can decrease so that each  $\text{res}[s]$  becomes  $-(n-1)L$ , meaning that we are doing on the order of  $2n^2L$  iterations. This is too slow, especially for non-distributed settings.

<sup>a</sup>This algorithm is also called *policy iteration* in reinforcement learning and is analogous to gradient descent.

A better way is to not be so random about how we choose the  $(u, v)$  in the while loop. Notice how we can lay out the shortest paths like a tree, so we can work in layers. The next algorithm implements this.

### Algorithm 7.0 (Bellman Ford with Smart Ordering)

We think of going in rounds indexed by  $t$ , and at every round, we are iterating through all the nodes and updating the shortest path of  $v$  using the shortest path of  $w$  included in all in-neighbors of  $v$ . At most, we will need to update this at most  $n$  times, which will guarantee convergence.

**Require:** Nodes  $V$ , Edges  $E$

```

1:  $\pi \leftarrow \text{list}(0)$  of large numbers of size  $|V|$ .
2:  $\pi[s] = 0$ 
3: function BELLMANFORD( $x$ )
4:   for  $t = 1, \dots, n - 1$  do
5:     for  $v \in V$  do
6:        $\pi^{(t)}[v] \leftarrow \min_w \{ \pi^{(k-1)}[v], \pi^{(k-1)}[w] + l_{wv} \}$ 
7:     end for
8:   end for
9: end function

```

The runtime is easier to see.

1. The step in the inner loop looks over the set of nodes of size  $\text{indeg}(v)$ .
2. Looping over all the nodes in the inner for loop means that we are going over all edges, so  $O(m)$ .
3. The outer for loop goes through  $n - 1$  times, so the total runtime is  $O(nm)$ .

### Example 7.2 (Bellman-Ford Walkthrough)

Let's conduct Bellman-Ford on the following graph. Thanks to this youtube video. Note that the graph below has a cycle  $A \rightarrow C \rightarrow B \rightarrow A$ , but it has a positive total weight, so this is fine.

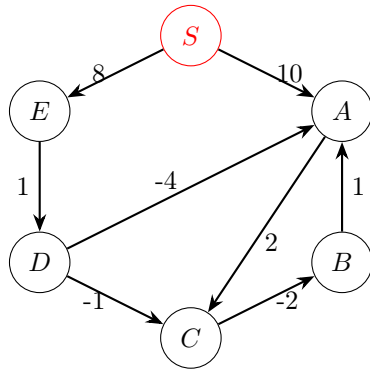

(a) We set  $\pi = [0, \infty, \infty, \infty, \infty, \infty]$ . Since there are 6 nodes, we will have 5 iterations and will go through the nodes expanding out from  $S$  of the order  $S, A, B, C, D, E$ , though we can go through in any order. That is, for each iteration, we will look at node  $X$  and all of its outgoing edges to its out neighbors  $Y$ , and we will update  $\pi[Y]$  accordingly. Doing this at iteration  $i$  will allow us to compute the shortest path to node  $Y$  up to length  $i$ .

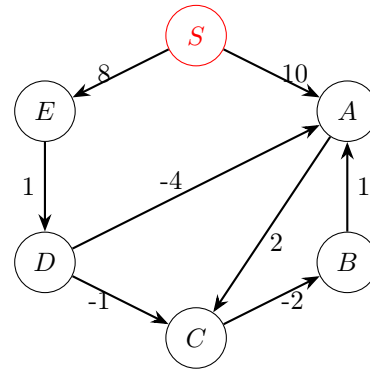

(b) 1st Iteration. The outgoing edges of  $S$  is  $A$  and  $E$  with total cost  $0 + 10 = 10$  and  $0 + 8 = 8$  and update  $\pi$ . For  $A$ , its out neighbors is  $C$  with total cost of  $10 + 2 = 12$ , so update  $\pi$ . Then for  $B$  we don't know how to reach it yet, so skip. For  $C$ , its out neighbors is  $B$  with total cost  $12 - 2 = 10$ . For  $D$ , we don't know how to reach it yet so skip. For  $E$ , its out neighbors is  $D$  with cost  $8 + 1$ , so update  $\pi$ . We have  $\pi = [0, 10, 10, 12, 9, 8]$ .

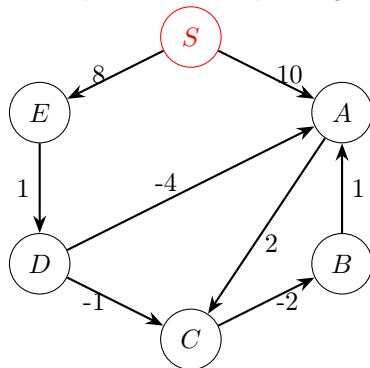

(c) 2nd Iteration. For  $S$  its outgoing edges are  $A$  and  $E$ , but there are no updates to do since it doesn't improve our distances. Same with  $A, B, C$ . For  $D$ , we can reach  $A$  with cost  $9 - 4 = 5$  and  $C$  with cost  $9 - 1 = 8$ , so update  $\pi$ . For  $E$ , there are no improvements, so skip this.  $\pi = [0, 5, 10, 8, 9, 8]$ .

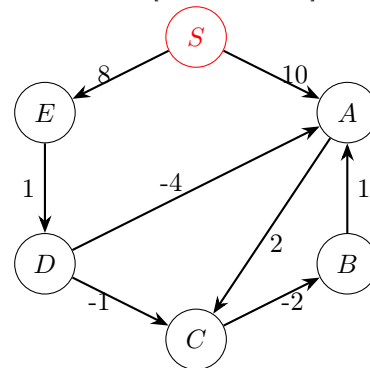

(d) 3rd Iteration. For  $S$ , there are no updates. For  $A$ , we can reach  $C$  with a cost of  $5 + 2 = 7$ , so update  $\pi$ . For  $B$ , there are no updates. For  $C$ , we can reach the out neighbor  $B$  with a cost of  $7 - 2 = 5$ , so update  $\pi$ . There are no more updates for the rest of the nodes  $C, D, E$ . So we have  $\pi = [0, 5, 5, 7, 9, 8]$ .

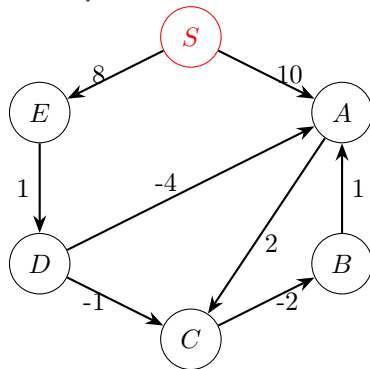

(e) 4th Iteration. We go through all the nodes and see that none of the weights have been updated. We are done.

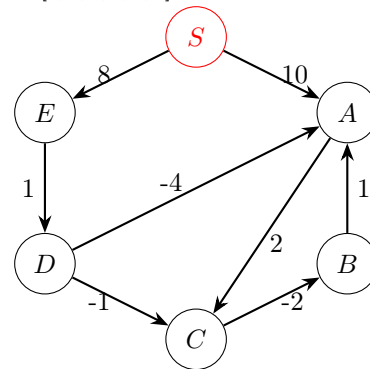

(f) The 5th iteration is not needed but it is needed in general.

Figure 36

### 7.5.1 All Pairs Shortest Graphs with Floyd Warshall

Now what if we want to find the minimum distance between all  $u, v \in V$ ? We can just use  $|V|$  Dijkstras or Bellman-Fords to get the appropriate runtimes of  $O(EV + V^2 \log V)$  or  $O(EV^2)$ , respectively, but for negative weighted graphs, there is a way to do this in  $O(V^3)$ .<sup>10</sup>

## 7.6 Minimum Spanning Trees

### Definition 7.5 (Spanning Tree)

Given an undirected graph  $G(V, E)$ , a **spanning tree** is a subgraph  $T(V, E' \subset E)$  that is

1. a tree, and
2. spans the graph, i.e. is connected

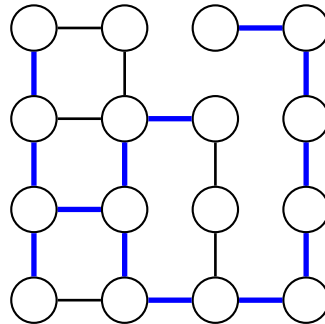

Figure 37: A spanning tree on a  $4 \times 4$  grid graph.

Note that an unconnected graph will never have a spanning tree, but what about a connected graph?

### Theorem 7.6 (Spanning Trees of Connected Graphs)

A connected graph will always have at least one spanning tree, not necessarily unique.

Given a connected undirected weighted graph, we may want to find the **minimum spanning tree (MST)**, i.e. the spanning tree with edges  $E'$  such that the sum of the weights of all  $e \in E'$  is minimized.<sup>11</sup> How do we do this? There are two well-known algorithms to solve this. Prim's and Kruskal's algorithm.

### 7.6.1 Prim's Algorithm with Cuts

Let's try to apply what we already know: Dijkstra. If we run Dijkstra on the graph starting at  $s \in V$ , we can get the shortest path from  $s$  to every other node in the graph. This will give us a tree, but it may not be minimum.

<sup>10</sup>Note that if the graph is sparse, then  $|E| < |V|$  and just running  $|V|$  Bellman Fords may be optimal.

<sup>11</sup>An application of this is when we generally want to make sparse graphs. In a datacenter, wires can be expensive, so how I can minimize the length of wires to buy to construct a spanning subgraph?

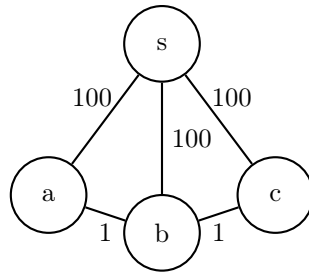

Figure 38: If we run Dijkstra on  $s$ , then our output will be a tree of cost 300, even when the actual MST can be of cost 102 starting from  $a$ .

It may seem like this is just a problem of where we start, but even this is not the case.

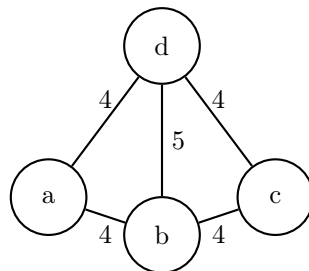

Figure 39: No matter where we start from, we will never output the MST. The MST has cost 12. If we start from  $b$  or  $d$ , we will get a tree of cost 13. If we start from  $a$  or  $c$ , we will get a tree of cost 16.

#### Definition 7.6 (Cuts)

Given graph  $G(V, E)$ , a **cut** is a partitioning of  $V$  into  $(S, V \setminus S)$ . Furthermore, let  $\text{Cut}(S)$  be the number of edges with exactly one endpoint in  $S$  and the other in  $V \setminus S$ .

#### Theorem 7.7 (Cycles and Cuts)

Given cycle  $C \subset E$  in a graph and a cut  $S \subset V$ ,

$$|C \cap \text{Cut}(S)| \quad (137)$$

is even. We can intuit this by visualizing the cycle as a long piece of looped string and a cut is a circle. The intersection between this circle and the string must be even since every time the cycle crosses through the cut, it must return back across the cut to the initial point.

Now time for a bizarre theorem.

#### Theorem 7.8 (Cut Property of MSTs)

For all cuts  $S \subset V$  of an undirected graph, the minimum cost edge in  $\text{Cut}(S)$  belongs to the MST. Furthermore, the converse is true: if we take all cuts and find all their minimum cost edges, these edges is precisely the MST! Therefore, an edge  $e \in \text{MST}$  iff  $e$  is a min-cost edge for some cut.

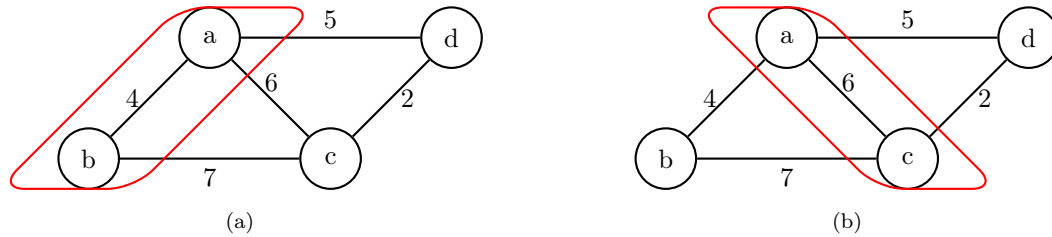

Figure 40: In the left cut, the edges are  $(a, d)$ ,  $(b, c)$ ,  $(a, c)$ . The minimum weight is 5 on the  $(a, d)$  edge, so it must be in the MST. For the right cut,  $(c, d)$  must be in the MST.

The final part is that if we have all edge costs different, then we will have a *unique* MST.

*Proof.* We use a greedy approach and prove by contradiction. Suppose that this is not true, i.e. there exists a cut  $S$  with minimum cost edge  $e$ , and  $e \notin \text{MST}$ . Then, there exists some other edge  $e' \in \text{Cut}(S)$  that is in the MST, since the MST is spanning and it must cross over to connect the whole graph. Well if we just put  $e$  in and take  $e'$  out, we will still have a spanning tree since it connects the left spanning tree to the right spanning tree, and we now have a cheaper tree. So the original cannot be the MST in the first place.

To prove the converse, consider some edge  $e$  in the MST and we must prove that it is the minimum cost edge in some cut. Note that if we take  $e$  out, then it divides the MST into two connected components, and we can just define the cut as these subsets of nodes. So this is in  $\text{Cut}(S)$  for some  $S \subset V$ . We can also prove that this is minimal since if it wasn't the minimum cost edge for some cut, we could have taken it out and inserted a cheaper edge  $e'$  to begin with, getting a cheaper spanning tree.

We can just brute force this logic into an algorithm by going through all possible cuts and adding the minimum cost edge to our MST set. It is clear that a cut is defined by a subset of  $S$ , so really the number of cuts a graph can have is  $2^{|S|-1}$ , which is exponential in  $n$ . However, the minimum spanning tree isn't exponential since it must have  $n - 1$  edges, so there must be many cuts with the same minimum edge.

One way is to start with one vertex  $a$  that contains the minimum cost edge  $(a, b)$  across all edges. This edge must be minimal and must be in the MST. Then we can look at the cut  $S = \{a, b\}$  and look at that cut. We keep doing this, keeping track of the set of edges we need to look at after adding a new node to our cut. So the number of cuts I consider is equal to the number of edges in the spanning tree.

#### Algorithm 7.0 (Prim's Algorithm to Find MST)

It turns out that we can modify Dijkstra to solve it.

**Require:** Graph  $G(E, V)$

1: **function** PRIM( $s$ )

2:  $S \leftarrow \{s\}$

▷Our initial cut

3:  $\pi[v] \leftarrow$  list of size  $|V|$  of  $+\infty$

▷ $\pi[u]$  is min cost of getting from  $u$  into the  $S$

4:  $\pi[v] = w_{sv}$  for all  $v \in V$

▷initialize list with neighboring nodes from start  $s$

5: **while**  $S \neq V$  **do**

6:  $u = \operatorname{argmin}_{v \notin S} \pi[v]$

▷Find node having minimum cost to reach from  $S$

7:  $S \leftarrow S \cup \{u\}$

▷Adding this node to  $S$  to expand our cut

8: **for**  $u \notin S$  **do**

▷Since we expanded  $S$ , our min reach distances

9:  $\pi[u] \leftarrow \min\{\pi[u], w_{wu}\}$

▷must be updated. It can only get shorter

10: **end for**

▷through a path from new  $u$ , so compare them

11: **end while**

12: **end function**

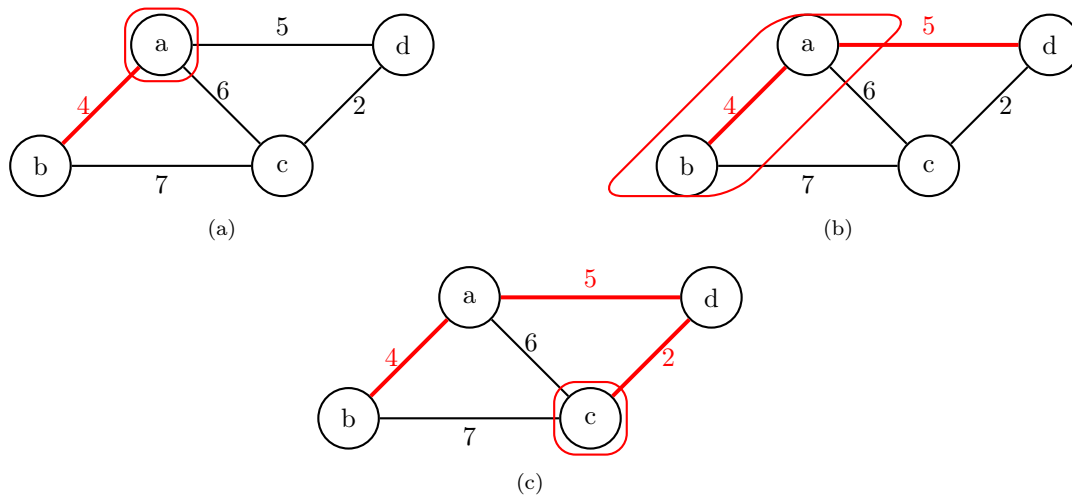

Figure 41: Step by step process of the method we mention above.

We are really going through two loops. We add to the cut  $S$   $n$  times and for each time we add, we must compute the argmin, which is also  $O(n)$ , so our total time complexity of  $O(n^2)$ .

However, this is not efficient, so we can introduce a minheap to get the argmin step faster.

**Algorithm 7.0 (Prim's Algorithm with MinHeap)****Require:** Nodes  $V$ , Edges  $E$ 

```

1: function PRIM( $V, E$ )
2:    $mst \leftarrow []$                                 ▷Initialize mst array to return
3:    $s \leftarrow 0$                                   ▷Choose any starting node
4:    $visited \leftarrow \text{set}()$                     ▷Our expanding set of cuts.
5:    $edges \leftarrow \text{minheap}()$                 ▷The set of low-weight edges that we can explore from
6:    $\text{add}(\text{weight}, s, \text{next\_node})$  for edges in  $E$   ▷Look for edges from  $s$  to expand our cut from.
7:   while  $|visited| < |V|$  do                    ▷Until we have visited all cuts,
8:      $\text{weight}, \text{frm}, \text{to} \leftarrow \text{pop}$  from edges  ▷Get the cheapest edge to explore
9:     if  $\text{to} \notin \text{visited}$  then                ▷If this isn't already in our cut,
10:       $\text{add}(\text{to}) \rightarrow \text{visited}$             ▷Add it to our cut. From cut
11:       $\text{add}(\text{frm}, \text{to}, \text{weight})$  to  $mst$         ▷property, this must be added to mst
12:      for  $\text{next\_to}, \text{next\_weight} \in E[\text{to}]$  do  ▷After expanding, add newly discovered
13:        if  $\text{next\_to} \notin \text{visited}$  then        ▷edges for future exploration
14:           $\text{push}(\text{next\_weight}, \text{to}, \text{next\_to})$  to edges
15:        end if
16:      end for
17:    end if
18:  end while
19:  return  $mst$                                     ▷of form (from, to, weight)
20: end function

```

You essentially push  $n$  times and pop  $m$  times, and the time per push and pop is  $\log_2(n)$ . Therefore, the total time to push is  $n \log(n)$  and to pop is  $m \log(n)$ , making the total runtime  $O((n+m)\log(n)) = O(m \log n)$ .

This can be sped up even faster if we use Fibonacci heaps or assume extra structure on the graph.

**7.6.2 Kruskal's Algorithm**

If we were to try and construct this algorithm from scratch, we may take a greedy approach by incrementally adding the minimum cost edge from your cut. However, there is one thing to check: have we entered a cycle? Checking whether the next added node  $a$  completes a cycle in  $S \cup \{a\}$  is nontrivial.

**Theorem 7.9 (Cycle Property)**

For all cycles  $C$ , the max cost edge of  $C$  does not belong to MST.

Therefore, you can take  $S$  and either add to it using the cut property or delete candidates from it using the cycle property. What is the best order to do this in? Kruskal's algorithm answers this question, which takes a greedy approach.

**Algorithm 7.0 (General Kruskal's Algorithm)**

The general idea is that we sort  $e \in E$  in increasing cost, and for each  $e \in E$ , we use either the cut or cycle property to decide whether  $e$  goes in or out.

**Require:** Graph  $G(V, E)$

```

1: function KRUSKAL(V, E)
2:   sort  $E$  in increasing cost
3:    $T \leftarrow \{\}$ 
4:   for  $e \in E$  do
5:     if  $T \cup \{e\}$  does not have cycle then
6:        $T \leftarrow T \cup \{e\}$ 
7:     else
8:       continue
9:     end if
10:  end for
11: end function

```

$\triangleright$ Cut property  
 $\triangleright$ Cycle property  
 $\triangleright$ discard  $e$  since from sorting, this edge is heaviest in cycle

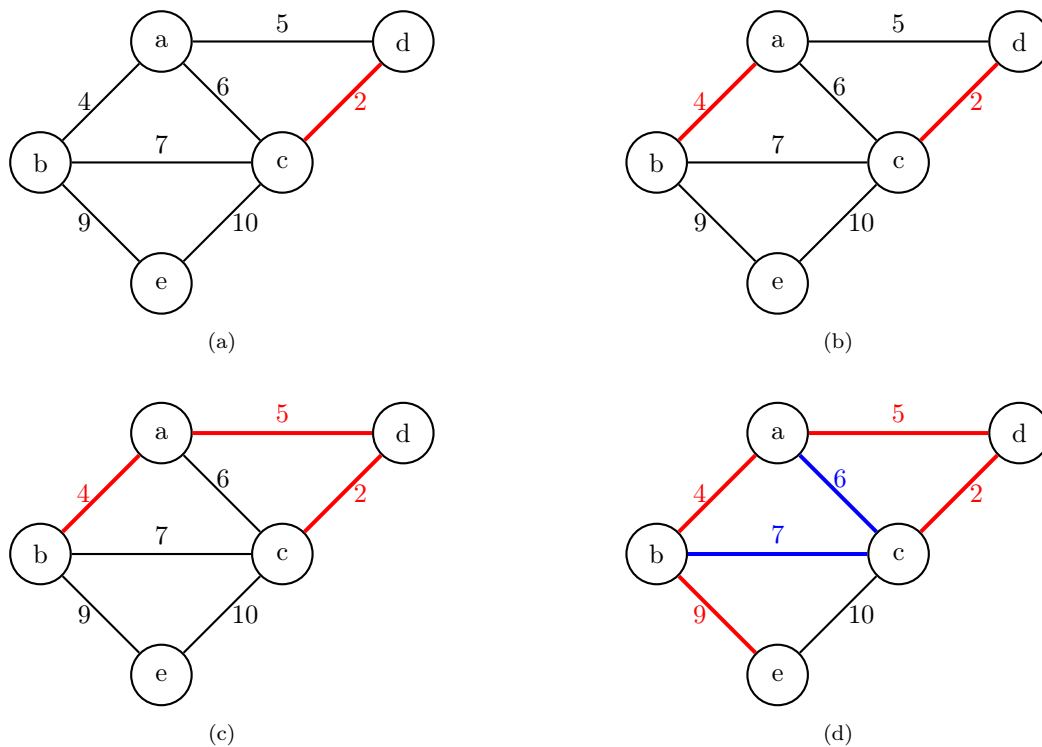

Figure 42: Kruskal's algorithm. In the last step, we see that the next minimum cost edge of 6 and 7 forms a cycle, so we add the edge of length 9.

The sorting of edges take  $O(m \log m)$  time, and after sorting, we iterate through all the edges and apply  $m$  find-union algorithm, which each take at most  $O(\log n)$  time. Therefore, the overall complexity is  $O(m \log m + m \log n)$ . However, the value of  $m$  can be at most  $O(n^2)$ , so the two logarithms are essentially the same, arriving at the final runtime of  $O(m \log n)$ .

The way to prove that this is correct is to show that every step you do is correct, known as *structural induction*, either because of one of the two properties. Say that so far, we have some edges in  $V$  which forms a partition of  $V = \sqcup_i T_i$  of disjoint trees (can be trees, one edge, or just single nodes). We are looking at the next biggest edge  $e = (a, b)$ . There are two possibilities.

1. If  $a, b$  are both in a single  $T_i$ , then this forms a cycle and can be thrown away since this is the max

cost edge in the cycle by the cycle property.

- If  $a, b$  connect  $T_i$  and  $T_j$  for  $i \neq j$ , then this edge is in  $\text{Cut}(T_i)$  and is the minimum cost edge since the rest of the edges in  $\text{Cut}(T_i)$  come next in the sorted  $E$ . Therefore this must be included by the cut property.

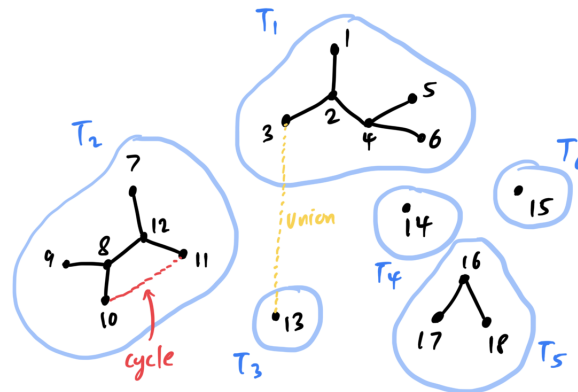

Figure 43: Each  $T_i$  is a component formed by the edges chosen so far. For example,  $T_1 = \{1, 2, 3, 4, 5, 6\}, \dots$ . We can either discard an edge (red) or include an edge (yellow).

The only bottleneck in here is line 5, where we check if  $e$  does not complete a cycle in  $T$ . It will obviously not be efficient to do BFS, construct a tree, and see if there is a loop by checking if two points in the same layer are connected. It may help to decompose this algorithm into two steps: what is being stored and what is being checked?

Note that from our visual, we are really just keeping a set of these points that each make a subtree and connecting them together. How do we efficiently search for which cluster a point is a part of and efficiently merge two clusters? We could use a hashmap but this wouldn't work. We need something like a doubly linked list.

#### Algorithm 7.0 (Kruskal's Algorithm)

The implementation uses the Union-Find data structure. For clarity, we will not elaborate it but will show the full pseudocode.

---



---

**Require:** Nodes  $V$ . Edges  $E = \{(u, v, w)\}$  where  $u, v \in V$  and  $w > 0$  is a weight.

```

function KRUSKAL( $V, E$ )
   $n \leftarrow |V|$ 
  sort  $E$  in increasing order of weights.
  parent  $\leftarrow [0, \dots, n - 1]$ 
  rank  $\leftarrow$  list of 0s of size  $n$ 
  function FIND( $x$ )
    if parent[ $x$ ]  $\neq x$  then
      parent[ $x$ ]  $\leftarrow$  Find(parent[ $x$ ])
    end if
    return parent[ $x$ ]
  end function
  function UNION( $x, y$ )
     $px, py = \text{find}(x), \text{find}(y)$ 
    if  $px = py$  then
      return False
    end if
    if rank[ $px$ ] < rank[ $py$ ] then
      parent[ $px$ ]  $\leftarrow py$ 
    else if rank[ $px$ ] > rank[ $py$ ] then
      parent[ $py$ ]  $\leftarrow px$ 
    else
      parent[ $py$ ]  $\leftarrow px$ 
      rank[ $px$ ]  $\leftarrow$  rank[ $px$ ] + 1
    end if
    return True
  end function
  mst  $\leftarrow []$ 
  for  $u, v, \text{weight} \in \text{edges}$  do
    if union( $u, v$ ) then
      add ( $u, v, \text{weight}$ ) to mst
    end if
    if len(mst) =  $n - 1$  then
      break
    end if
  end for
  return mst
end function

```

To analyze the runtime of this, we define the function.

#### Definition 7.7 (Ackerman Function)

The **Ackerman function** is one of the fastest growing functions known. It is practically infinity.

$$A(m, n) = \begin{cases} n + 1 & \text{if } m = 0 \\ A(m - 1, 1) & \text{if } m > 0 \text{ and } n = 0 \\ A(m - 1, A(m, n - 1)) & \text{if } m > 0 \text{ and } n > 0 \end{cases} \quad (138)$$

The inverse Ackerman function therefore grows extremely slowly.

If we optimize the steps in Kruskal's algorithm, we can get its runtime to

$$O((m+n)\log^*(n)) \quad (139)$$

which is practically linear.

### 7.6.3 Applications

Here is a way to cluster data, a surprising way to apply MSTs. It is the most widely used application, especially in data science. The problem is that given  $n$  data points  $x_i \in \mathbb{R}^d$  and an integer  $k$ , we want to partition the points into  $k$  groups  $\mathbf{C} = (C_1, \dots, C_k)$  where  $\mathbf{x} = \sqcup_i C_i$ . You want to distances between the points within a group to be small and the distances between groups to be large. We can think of finding the objective which takes every pair of clusters and computes the minimum distance between these clusters, and we want to maximize this distance over all pairs of clusters.

#### Algorithm 7.0 (Single Linkage/Hierarchical Clustering)

The general idea is to take this dense graph, find the MST, and cut off the largest edges from this MST, which will give you  $k$  components. This is the answer. Or really, you can use Kruskal's algorithm and terminate earlier when  $T$  has  $k$  sets/components. Note that as we add edges as we construct our MST, we are merging two clusters into one. So that all you are doing is finding the next pair of closest points and merging the clusters that they are a part of.

**Require:** Nodes  $V = \{v_i\} \subset \mathbb{R}^n$

- 1: **function** CLUSTER( $V$ )
- 2:     Run Kruskal and at each iteration, check if you have  $K$  clusters.
- 3:     If so, terminate and return the **parent** list.
- 4: **end function**

#### Theorem 7.10

The algorithm above minimizes the objective function.

$$\operatorname{argmax}_{\mathbf{C}} \min_{p \in C_i, q \in C_j} \{d(p, q)\} \quad (140)$$

*Proof.* Let  $\mathbf{C}^*$  be the MST clustering. We claim that for any other clustering  $\mathbf{C} = \{C_1, \dots, C_k\}$ ,

$$\operatorname{mindist}(\mathbf{C}) \leq \operatorname{mindist}(\mathbf{C}^*) \quad (141)$$

Assume that this was not the case, so  $\operatorname{mindist}(\mathbf{C}) > \operatorname{mindist}(\mathbf{C}^*)$  and therefore there exists a  $p, q \in C_i, C_j$  such that  $d(p, q) = \operatorname{mindist}(\mathbf{C}) > \operatorname{mindist}(\mathbf{C}^*)$ . Since this is a different clustering,  $p, q$  must have been in the same cluster  $C_i^*$ . But note that since Kruskal adds edges in increasing length, all edges within a cluster must have length less edges that go across two clusters.

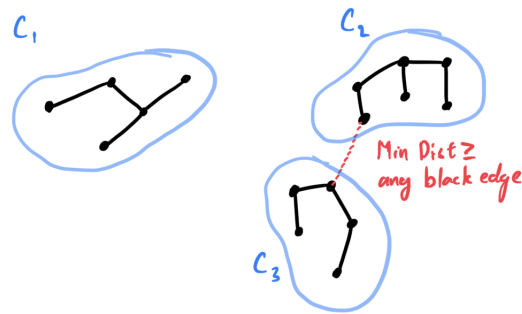

So  $d(p, q)$  must be less than the length of all edges within a cluster in  $\mathbf{C}^*$ . But all within-cluster edges must be smaller than  $\text{mindist}(\mathbf{C}^*)$ , meaning that  $\text{mindist}(\mathbf{C}^*) > d(p, q)$ , contradicting the fact that is is greater, and we are done.

If you define the distance between two clusters to be the distance between the centroids (mean point), then this is called *average linkage* (min avg distance). If we define the cluster distance as the maximum distance between two points, then it is called *complete linkage* (min max distance). Kruskal's algorithm only worked for the single linkage case but may not work for these additional definitions. This is why there is usually a whole suite of clustering algorithms for a particular problem and we just find out which one fits the data the best. Furthermore, we have done *bottom-up clustering*, where we took individual points to make clusters. In *top-down clustering*, we take the whole set and cut it up into clusters.

## 7.7 Maximum Flows and Minimum Cuts

### Definition 7.8 (Flow Network)

Given a nonnegative weighted directed graph  $G(V, E)$ , we can define the weights to be the **capacity**  $C : E \rightarrow \mathbb{R}^+$  of some commodity that can travel through the edge. Say that we have a source node  $s \in V$  and a sink/destination node  $t \in V$ . This is called a **flow network**.

### Definition 7.9 (Flow)

Given a flow network, a **flow** is a function  $f : E \rightarrow \mathbb{R}^+$  satisfying

1. *Conservation*. What flows in must always flow out. For all  $v \neq s, t$ , we have

$$\sum_{(u \rightarrow v) \in E} f(u \rightarrow v) = \sum_{(v \rightarrow w) \in E} f(v \rightarrow w) \quad (142)$$

2. *Feasibility*. We cannot exceed the capacity. For all  $e \in E$ ,

$$0 \leq f(e) \leq C(e) \quad (143)$$

The **value** of a flow represents the actual/realized amount of the commodity that we can push through the graph

$$|f| = \sum_{(s \rightarrow u) \in E} f(s \rightarrow u) - \sum_{(u \rightarrow s) \in E} f(u \rightarrow s) \quad (144)$$

where we need to subtract the right expression to avoid loops.

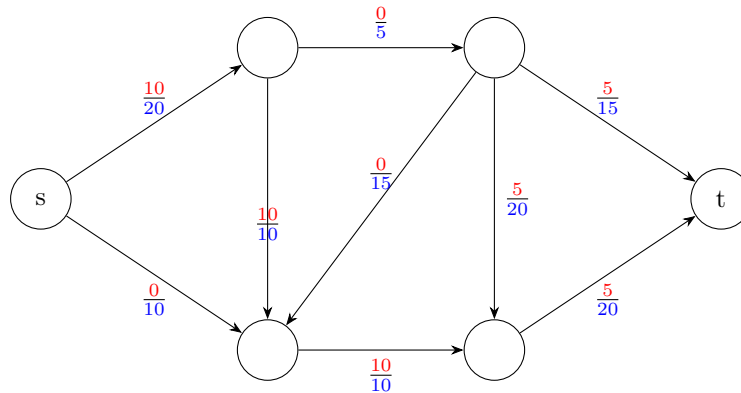

Figure 44: The red values represent the flow. The blue values represent the capacity. The value of the above flow is 10.

Now let's revisit cuts.

#### Definition 7.10 (Cuts)

Given a flow network, a  $s$ - $t$  **cut** is a partition of  $V = S \sqcup T$  s.t.  $s \in S, t \in T$ . The **value**, or **capacity**, of a cut is defined as the capacity of its edges

$$||S, T|| = \sum_{u \in S} \sum_{v \in T} C(u \rightarrow v) \quad (145)$$

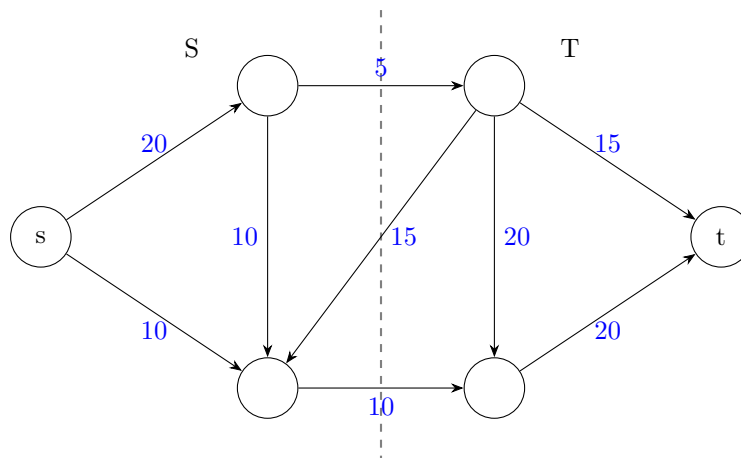

Figure 45: This cut has capacity 15. Note that the cut going from right to left is not included since this is a  $S$ - $T$  cut.

We now introduce two related problems.

1. Max Flow. How do we find the flow with the maximum value? This is analogous to maximizing the commodity transport from  $s$  to  $t$ .
2. Min Cut. How do we find the cut with the minimum capacity? This is analogous to removing the smallest total edges that will disconnect  $s$  to  $t$ .

It turns out that they are pretty much the same problem.

**Theorem 7.11 (Max-Flow Min-Cut Theorem)**

For any valid  $(s, t)$  flow  $f$  on a flow network  $G = (V, E)$  and any valid  $(s, t)$ -cut  $S, T$ , we have

$$|f| \leq \|S, T\| \quad (146)$$

It also turns out that equality is achieved, which immediately implies that the max-flow is the min-cut.

*Proof.* We can see that in order for a flow to have a value, given some cut the flow value cannot exceed the capacity through this cut from  $S$  to  $T$ . Mathematically, we can see that the flow value is invariant due to conservation, and so

$$|f| = \sum_{s \rightarrow v} f(s \rightarrow v) - \sum_{v \rightarrow s} f(v \rightarrow s) \quad (147)$$

$$= \sum_{u \in S} \sum_{v \in T} f(u \rightarrow v) - \sum_{v \in T} \sum_{u \in S} f(v \rightarrow u) \quad (148)$$

$$\leq \sum_{u \in S} \sum_{v \in T} c(u \rightarrow v) = \|S, T\| \quad (149)$$

The fact that equality is achieved is highly nontrivial, and we will not cover it here.

Therefore, to solve for minimum cuts, we can try and compute the maximum flow. To do this, we will need to define *residual networks*, which a representation of a flow network. For now, we will assume that a flow network  $G$  does not have 2-cycles (cycles of length 2), and if we do find a graph with such a 2-cycle, we modify it by adding an intermediate node.

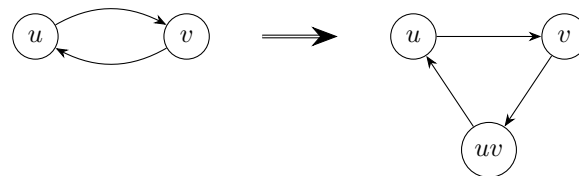

Figure 46: How we modify our 2-cycle.

**Definition 7.11 (Residual Network)**

Given a flow network  $G$  and a flow  $f$ , the **residual graph**  $G_f$  is a new flow network that has edges  $u \rightarrow v$  and  $v \rightarrow u$ , where

$$c_f(u \rightarrow v) = \begin{cases} c(u \rightarrow v) - f(u \rightarrow v) & \text{if } u \rightarrow v \in E \\ f(u \rightarrow v) & \text{if } v \rightarrow u \in E \end{cases} \quad (150)$$

Basically, if there is some flow in an edge, we replace that edge's capacity by the residual capacity, giving us our *forward edge*, and then take this flow and add it to a new opposite pointing edge, called the *backwards edge*.

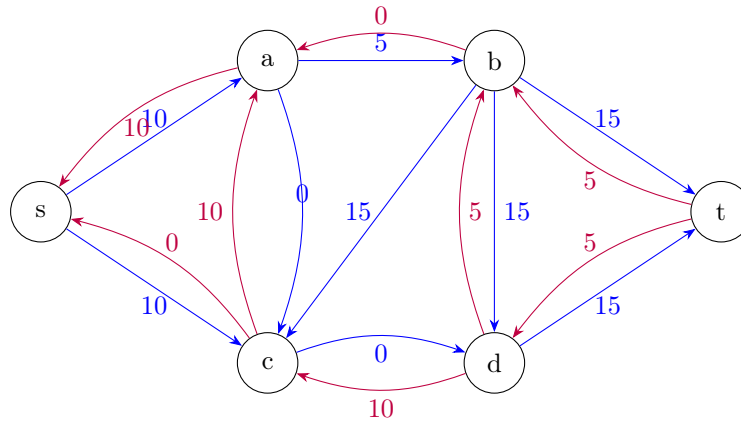

Figure 47: The residual network consists of both the forward (blue) and backwards (red) edges.

This residual just seems like another way of looking at the same data, and it is. But it reveals a way for us to use what we know to increase the flow.

### Theorem 7.12 (Augmenting Paths on Residual Networks Improves Flow)

If we have a flow  $f$ , its value  $|f|$  can be improved/augmented up to the bottleneck capacity on any residual path. That is, if we find any  $s \rightarrow t$  path  $\pi$  on  $G_f$ , with a positive bottleneck capacity (minimum capacity over its edges), we can improve the flow.<sup>a</sup> Given this residual path  $\pi$ , it may have both forward or backwards edges. To augment the original path on  $G$  by value  $b$ , we look at each edge  $(u \rightarrow v) \in E$  and

1. If it corresponds to a forward edge (i.e. if  $(u \rightarrow v)$  is in the residual path  $\pi$ ), we add  $b$ . This corresponds to how much more flow you can put into this edge.
2. If it corresponds to a backward edge (i.e. if  $(v \rightarrow u)$  is in the residual path  $\pi$ ), we subtract  $b$ . This corresponds to how much flow could you reroute in the backwards direction and have it reach  $t$  through another path.
3. If it is not in  $\pi$ , then we don't change it.

In summary, the new flow  $f'$  is defined

$$f'(u \rightarrow v) = \begin{cases} f(u \rightarrow v) + b & \text{if } (u \rightarrow v) \in \pi \\ f(u \rightarrow v) - b & \text{if } (v \rightarrow u) \in \pi \\ f(u \rightarrow v) & \text{else} \end{cases} \quad (151)$$

<sup>a</sup>For example, the capacity of the path  $S, C, A, B, T$  is 5, since  $A \rightarrow B$  has weight 5.

*Proof.* We first show that  $f'$  is a valid flow. For feasibility,

1. *Forward.* If  $(u \rightarrow v) \in \pi$ , then

$$f'(u \rightarrow v) = f(u \rightarrow v) + b \leq f(u \rightarrow v) + c_f(u \rightarrow v) = c(u \rightarrow v) \quad (152)$$

2. *Backward.* If  $(v \rightarrow u) \in \pi$ , then

$$f'(u \rightarrow v) = f(u \rightarrow v) - b \geq f(u \rightarrow v) - c_f(v \rightarrow u) = 0 \quad (153)$$

For conservation, there are 4 cases.

1. Forward into node, forward out of node.  $\Delta_{in} = +b, \Delta_{out} = +b$ . Therefore the flows cancel out.
2. Forward into node, backward out of node.  $\Delta_{in} = +b - b = 0$ .
3. Backward into node, forward out of node.  $\Delta_{out} = +b - b = 0$ .
4. Backward into node, backward out of node.  $\Delta_{in} = -b, \Delta_{out} = -b$ .

We've reduced this problem to a problem of finding a positive path  $\pi$  in the residual graph, which we have a lot of algorithms built for, such as DFS, BFS, or Dijkstra. This general algorithm is known as *Ford-Fulkerson*, and the specific implementation in which we use BFS to find these paths is called *Edmonds-Karp*.

### Algorithm 7.0 (Ford-Fulkerson, Edmonds-Karp)

The general idea is that we construct the residual graph, and find any path from source  $s$  to sink  $t$ . Then we augment this path in  $G_f$  by the bottleneck capacity, which guarantees that the flow on  $G$  will be improved. We keep doing this until we cannot find such a path anymore. Note that this is a type of greedy algorithm.

---

**Require:** Flow network  $G(V, E)$ , source/sink  $s, t \in V$ . Capacity  $c$ .

**function** MAXFLOW( $G$ )

Start with the trivial flow  $f$ , maybe stored as array  $[0, \dots, 0]$  of length  $E$ .

Construct residual graph  $G_f$  for this trivial flow.

**while**  $G_f$  has an augmenting path in  $G_f$  **do** ▷Maybe use BFS to find this.

    Pick  $\pi$  as any augmenting path

    augment  $f$  by bottleneck capacity

    update  $G_f$ .

**end while**

**return**  $f$

Use BFS to find all nodes in  $G_f$  reachable from  $s$ . Call this  $S$ .

Let  $T = V \setminus S$ .

$S, T$  is our min cut, and  $f$  is your max flow.

**end function**

---

The inner loop is just BFS, which is  $O(N + M)$ , but how many iterations do we do? Well for integer capacities, we can bound it by the actual value of the max flow  $|f^*|$  since we must improve by at least  $+1$  every loop.<sup>a</sup> Unfortunately,  $O((N + M)|f^*|)$  is the best we can do in generality, which is pseudopolynomial.

---

<sup>a</sup>This is not a trivial result that if all capacities are integers, then there is an integer max-flow, despite the actual flow being dispersed as fractions across edges.

Note that once the algorithm terminates, this means that we cannot find a path to augment. At this point, we can use BFS to look at all vertices  $S \subset V$  reachable from  $s$  in  $G_f$ , and then let  $T = V \setminus S$ . These two disjoint sets will give the min cut. There are indeed polynomial time algorithms, e.g. Orlin's algorithm with runtime  $O(NM)$ , which is guaranteed to be polynomial but in practice may be slower.

### Example 7.3 (Ford-Fulkerson Walkthrough)

Let's conduct Ford-Fulkerson on the following graph. Each row consists of one step, which is to find an augmenting path, compute the bottleneck capacity, and augment each edge and the total flow.

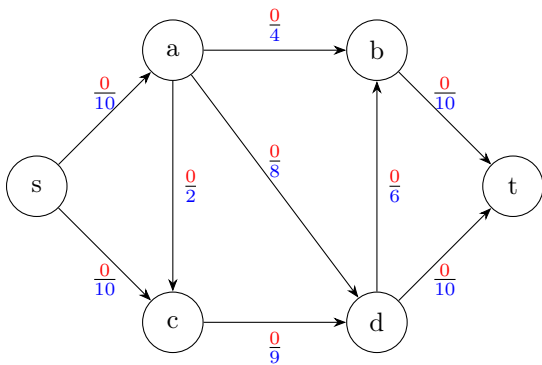

(a) Our initial graph  $G$  with our capacity in blue and trivial flow in red.

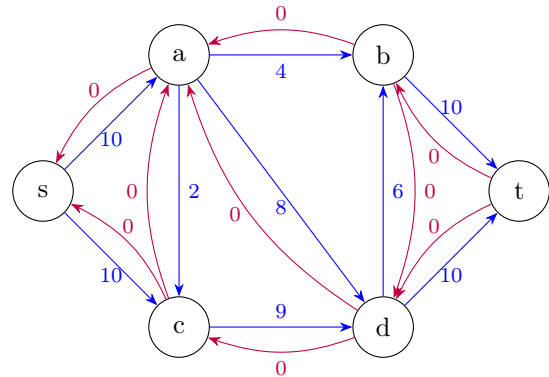

(b) Our residual network  $G_f$  consists of all the blue and red edges.

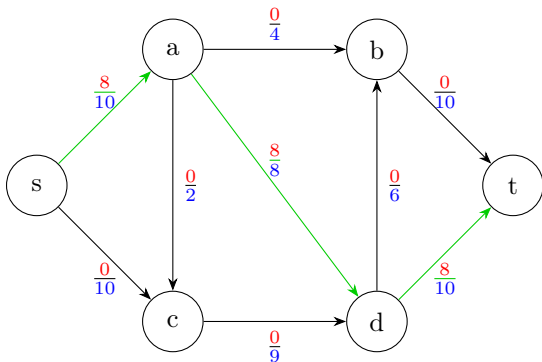

(c) We run BFS and find a path, say  $s \rightarrow a \rightarrow d \rightarrow t$ . The bottleneck capacity is 8 from min weight edge  $a \rightarrow d$ .

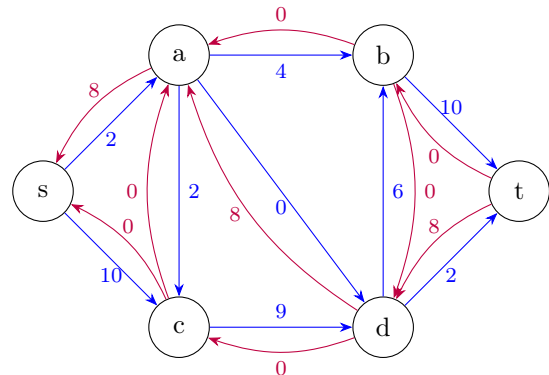

(d) We decrease our forward edges and increase our backwards edges along this path. We have a total flow of 8.

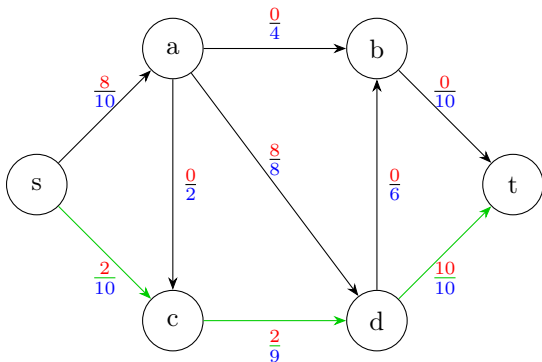

(e) We run BFS again and find the path  $s \rightarrow c \rightarrow d \rightarrow t$ , with a bottleneck capacity of 2, from  $d \rightarrow t$  which is partially full and has remaining capacity  $2/10$ .

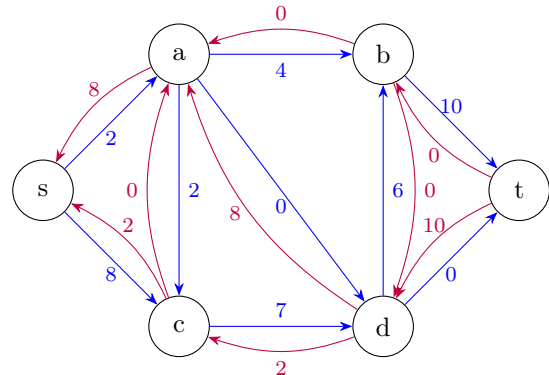

(f) We update our forward and backwards edges along this path, with a total flow of 10.

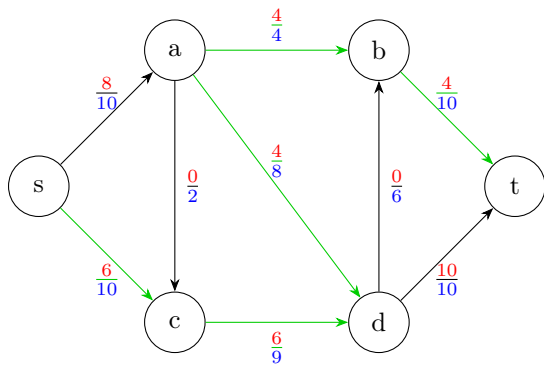

(g) Now we run BFS and come across a path that has a backwards edge. See that  $s \mapsto c \mapsto d \mapsto a \mapsto b \mapsto t$  contains the backwards edge  $d \mapsto a$  which has capacity 8. This path has capacity 4 (from  $a \rightarrow b$ ).

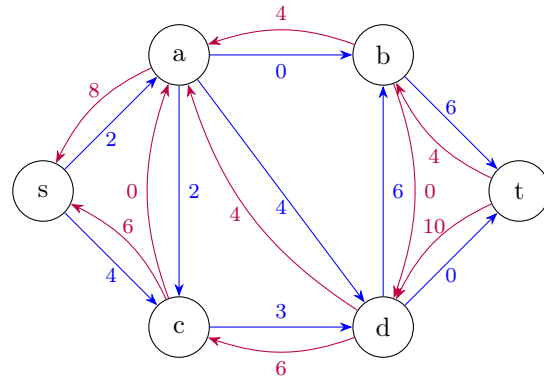

(h) We increment the flow on all the forward edges and decrement the flow on the backwards edge  $a \rightarrow d$ . We are shifting the flow from  $a \mapsto d$  to  $a \mapsto b$ , leaving space for more flow. Total flow of 14.

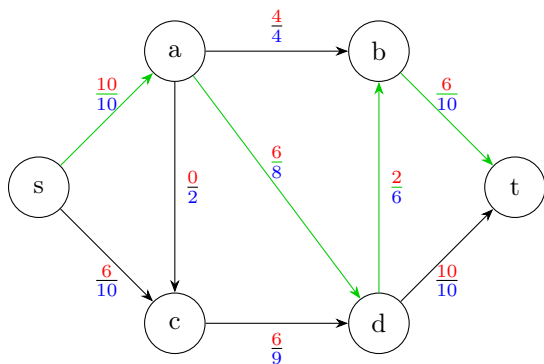

(i) We find the path  $s \mapsto a \mapsto d \mapsto b \mapsto t$  and increment by bottleneck of 2.

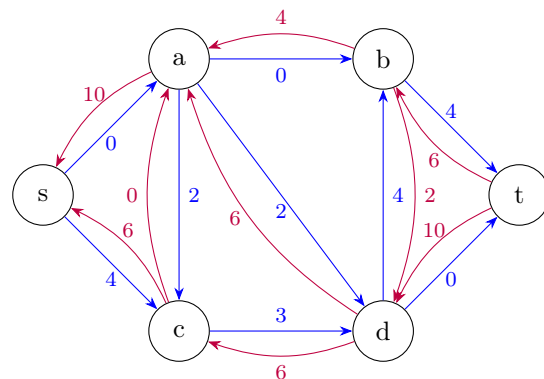

(j) This consists of all forward edges, so we don't have to do anything fancy here. Total flow of 16.

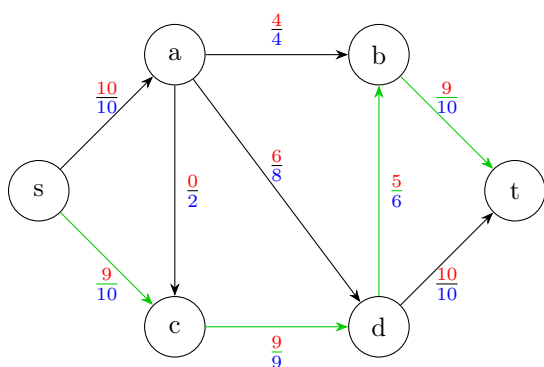

(k) Same on the path  $s \mapsto c \mapsto d \mapsto b \mapsto t$ .

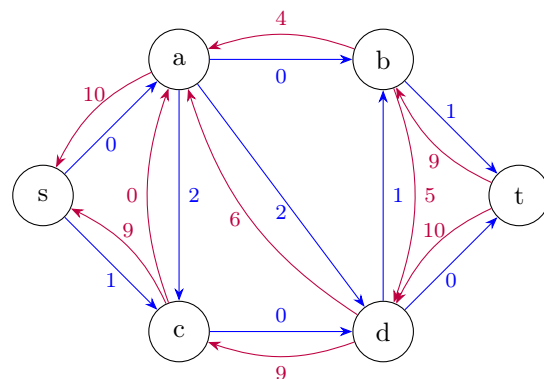

(l) Increment all forward edges for total flow of 19.

At this point, we try to find another path. The path  $s \mapsto a$  is full so we cannot go through there.  $s \mapsto c$  has a capacity of 1, but from  $c$ ,  $c \mapsto d$  has a full capacity (so we cannot add to it), and  $c \mapsto a$  has a backwards edge  $c \mapsto a$  is empty (so we cannot remove from it). Therefore there are no more paths<sup>a</sup> and we are done.

<sup>a</sup>We could have found this again using BFS.

**Example 7.4 (Edge Disjoint Paths)**

Given a directed graph  $G(V, E)$  with start and end nodes  $s, t \in V$ , we want to find the maximum number of paths from  $s \rightarrow t$  s.t. they do not share any edge, i.e. are *edge-disjoint*.

Figure 49: This graph has two edge-disjoint paths: the top and bottom paths.

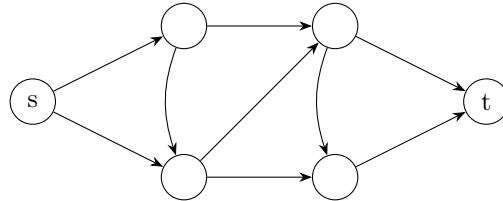

The idea is to reduce the maximum flow by first assigning capacity 1 to every edge. Then we compute the maximum flow  $f^*$ , and then return  $|f^*|$ . It turns out that even if we chose a path  $\pi$  that went through the center node, the augmentation would push us to redirect the flows to the top and bottom outer edges. Since  $|f^*| \leq n - 1 < m$  in this example (since it can be at most the maximum indegree or outdegree of  $s, t$ ), we should probably use Ford-Fulkerson rather than Orlin's algorithm.

This leads to the lemma.

**Theorem 7.13 (Edge-Disjoint Paths)**

Given directed graph  $G$  and its corresponding flow network  $G'$  of capacity 1, the following are true:

1. If there exists  $k$  edge-disjoint paths in  $G$ , then there exists a flow with value  $\geq k$  in  $G'$ .
2. If there exists a flow of value  $k$  in  $G'$ , then there exists  $k$  edge-disjoint paths in  $G$ .

*Proof.* The first is trivially feasible and conservation is satisfied since for any node  $u \in V \setminus \{s, t\}$ , every path in  $P$  (the collection of  $k$  paths) that enters  $u$  must exit  $u$ , so the total flow in equals the total flow out  $\implies f$  is a valid  $(s, t)$ -flow. Therefore, we have  $k$  paths leaving  $s$ , so  $|f| = k$ .

For the other direction, let  $f$  be the flow with value  $k$ , and let  $P = \{\}$ . Let  $H$  be the subgraph of  $G'$  of edges with positive flow, and for every loop, we use BFS from  $s$  to  $t$  to get a path  $\pi$ . We then add  $\pi$  to  $P$  and remove  $\pi$  from  $H$ , repeat this  $k$  times until we get  $k$  paths in  $P$ .

The way that we have constructed a collection of paths from a flow function is very useful, and is called *flow decomposition*. We can go back and forth between a flow and a collection of paths by doing what we have just done in the previous proof.

**Definition 7.12 (Flow Decomposition)**

Given a general flow  $f$  on flow network  $G$ , we initialize our set of paths  $P = \{\}$  and loop the following:

1. Use BFS from  $s$  to  $t$  to get a path  $\pi$ .
2. Add  $\pi$  to  $P$  and rather than strictly removing the path from  $H$ , we need to be mindful of how much flow is left on it after removing only the bottleneck flow on the path.

This can be done in  $O(NM)$  time, which loosely is because we are running BFS  $O(M)$  times.

**Example 7.5 (Undirected Edge-Disjoint Paths)**

What if  $G$  is undirected? In this case, we want to construct a flow network and then convert its 2 cycles into a 3 cycles by adding artificial points, taking linear time.

**Example 7.6 (Undirected Edge-Disjoint Paths)**

Another problem is about vertex-disjoint paths, which is a stronger restriction than edge-disjoint ones. Each node does not have a concept of a capacity, so the general idea is for each vertex  $v$ , replace it with an “in-out gadget” with an edge of weight 1. The rest of the details follow similarly from edge-disjoint paths.

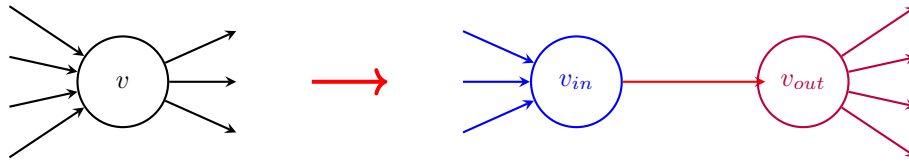

Figure 50

**Example 7.7 (Maximum Bipartite Matching)**

Another application is in **bipartite matching**, which for an undirected bipartite graph  $G(V, E)$  with  $V = A \sqcup B$ , is a subset of the edges  $M \subset E$  s.t. no 2 edges in  $M$  share an endpoint. The goal is to find the maximum bipartite matching, i.e. the matching with the greatest total weight.

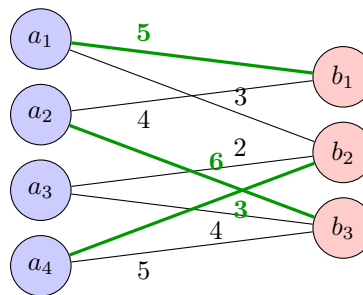
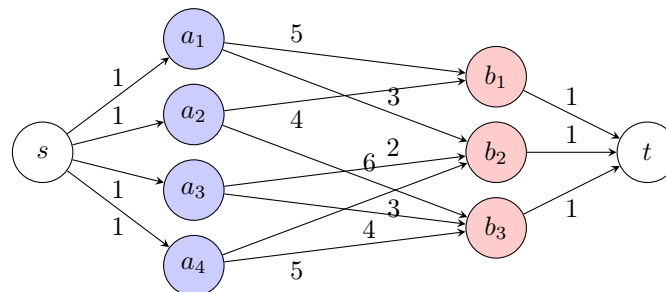

Figure 51: A bipartite matching

The general idea is to take an undirected graph, convert it to a flow network, compute the max flow, i.e. min cut, and then translate it back into the undirected graph solution.

1. Construct the flow network  $G' = (V', E')$ , where  $V' = V \cup \{s, t\}$ , with additional edges going from  $s$  to  $A$  and  $B$  to  $t$  all with weights 1. Replace the middle edges with directed edges towards the flow with the same weight (though it can be any weight at least 1).



2. Compute max flow  $f$  in  $G'$ .
3. Return  $M = \{(u \rightarrow v) \in E \mid f(u \rightarrow v) = 1\}$ . This can be done using the flow decomposition or just by looking at the edges in our flow with value 1 and mapping it to the corresponding undirected bipartite graph.

To see correctness, we claim that there exists a matching  $M$  in  $G$  of size  $k$  iff there exists a flow  $f$  in  $G'$  with  $|f| = k$ , and therefore the max matching corresponds to the max flow. Constructing the flow network is  $O(N + M)$  since  $N' = N + 2$  and  $M' = M + N$ . Computing the max-flow is  $O(N'M')$  or  $O(M'|f|)$  depending on if we use Orlin's or Ford-Fulkerson, but either one is  $O(NM)$ . Then mapping it back to  $M$  might take  $O(M)$ , so the total time is  $O(NM)$ .

## 7.8 Exercises

### Exercise 7.1

Prove that in any connected undirected graph  $G = (V, E)$  there is a vertex  $v \in V$  s.t.  $G$  remains connected after removing  $v$ .

*Solution.* Let  $u$  be such a leaf node of  $T$ , and let  $G'$  be the subgraph of  $G$  resulting by removing  $u$  and its incident edges from  $G$ . For sake of contradiction,<sup>a</sup> suppose  $G'$  has more than one connected component. Let  $C$  be a connected component in  $G'$  that does not contain  $s$ , the root of the BFS tree  $T$ . Since  $G$  was connected before the removal of  $u$ , it must be that every path from  $s$  to any vertex  $v$  in  $C$  includes  $u$  (otherwise there would remain a path from  $s$  to  $v$  in  $G'$  and  $s$  would be in  $C$ ). Then  $u$  is the only vertex not in  $S$  with edges to vertices in  $S$ , so all vertices in  $C$  must be “visited” during BFS only after visiting  $u$ . Furthermore, the vertices of  $S$  must be in the subtree of  $T$  rooted at  $u$ . But  $u$  is a leaf, which is a contradiction.

<sup>a</sup>We provide an alternative direct proof as follows: Since  $G$  is given to be connected,  $T$  contains all vertices of  $G$ . Let  $T'$  be the BFS tree minus  $u$  and its single incident edge connecting it to its parent in  $T$ . Since  $u$  is a leaf,  $T'$  remains a connected tree with all other vertices of  $G$ . The edges of  $T'$  exist in  $G'$ , so  $G'$  is connected.

### Exercise 7.2

Two parts.

1. Give an example of a strongly connected directed graph  $G = (V, E)$  s.t. that every  $v \in V$ , removing  $v$  from  $G$  gives a directed graph that is not strongly connected.
2. In an undirected graph with exactly two connected components, it is always possible to make the graph connected by adding only one edge. Give an example of a directed graph with two strongly connected components such that no addition of one edge can make the graph strongly connected.

*Solution.* Listed.

1. A graph whose edges form a cycle, having at least three nodes.
2. Two strongly connected components with no edges between them.

### Exercise 7.3 (DPV 3.16)

Suppose a CS curriculum consists of  $n$  courses, all of them mandatory. The prerequisite graph  $G = (V, E)$  has a node for each course, and an edge from course  $v$  to course  $w$  if and only if  $v$  is a prerequisite for  $w$ . Note this is a directed acyclic graph (DAG). In order for a student to take a course  $w$  with prerequisite  $v$ , they must take  $v$  in an earlier semester. Find an algorithm that works directly with this graph representation, and computes the minimum number of semesters necessary to complete the curriculum, under the assumption any number of courses can be taken in one semester. The running time of your algorithm should be  $O(n + m)$ , where  $n$  and  $m$  are the numbers of vertices and edges in  $G$ , respectively.

*Solution.* For each vertex, we want to find the longest path leading to it: if there is a path leading to a node, then all of the courses in the path should be taken sequentially. Perform a topological sort of  $G$ 's nodes and label them 1 through  $n$ . Then, we go through the nodes in the resulting topological order. For each vertex, we assign the minimum number of semesters required to take it: if there are no prerequisites, we assign 1, and if there are prerequisites, we assign 1 plus the maximum value assigned to its prerequisite nodes.

*Implementation details:* If the input is in adjacency list format, then we do not have access to the *incoming* edges to a node (its prerequisites). By exploring the entire graph with BFS calls, we can compute the list of incoming edges to every vertex in  $O(n + m)$  time. These details are not required. If the input is in adjacency matrix format, for each node it takes  $O(n)$  time to find its incoming edges, so the total running time is  $O(n^2)$ .

#### Exercise 7.4 (DPV 3.22)

Give an efficient algorithm that takes as input a directed graph  $G = (V, E)$ , and determines whether or not there is a vertex  $s \in V$  from which all other vertices are reachable.

*Solution.* We first build the DAG representation of the SCCs of  $G$  in  $O(m + n)$  time, as described in lecture. This graph is a DAG where each SCC of  $G$  is represented by a single node. We return true if this DAG has exactly one node with no incoming edges (i.e., exactly one source node), and return false otherwise.

*Correctness.* Let  $u$  be a vertex in an SCC that is a source node in the DAG representation. If there is a path in  $G$  from a vertex  $v$  not in the SCC of  $u$  to  $u$ , then there must be an edge (corresponding to an edge in this path) into the SCC of  $u$  in the DAG, which contradicts that the node has no incoming edges. Thus, if there are two source SCCs in the DAG, no vertex of  $G$  can reach all vertices; in particular, no vertex can reach the vertices in both of the source SCCs. Thus we correctly return false if there are multiple source SCCs.

On the other hand, if there is a single source SCC in the DAG, we claim that every vertex in the SCC can reach every other vertex in  $G$ , in which case our algorithm correctly returns true. Every other SCC in the DAG is not a source, so it has an incoming edge.<sup>a</sup> Consider starting at an SCC in the DAG, picking an incoming edge to the SCC, and then repeating this process from the SCC from which the edge was leaving. This process stops when we reach an SCC without incoming edges. In this case there is exactly one source SCC, so this process will arrive at the single source SCC when starting from any SCC in the DAG. This implies there is a path from the unique source SCC to every other SCC in the DAG, and thus every vertex of the source SCC can reach all vertices in all SCCs of  $G$ ; that is, all vertices of  $G$ .

<sup>a</sup>The following argument can be made formal with induction.

#### Exercise 7.5 (DPV 3.19)

You are given a binary tree  $T = (V, E)$  with designated root node with  $n = |V|$  vertices which are the integers from 1 to  $n$ . In addition, there is an array  $x[1..n]$  of values where  $x[u]$  is the value of vertex  $u \in V$ . Define a new array  $z[1..n]$  where, for each  $u \in V$ ,

$$z[u] = \max\{x[v] \mid v \text{ is a descendant of } u\} \quad (154)$$

That is,  $z[u]$  is the maximum  $x$ -value of all vertices in the subtree of  $T$  rooted at  $u$ . Note that, by definition, any node is a descendant of itself. Describe an  $O(n)$ -time algorithm which calculates the entire  $z$ -array.

*Solution.* We propose the following recursive algorithm performs a *postorder* traversal of the tree and populates the values of the  $z$ -array in the process:

```

1 computeZ(u):
2   maxVal = x[u]
3   if u.left is not null:
4     computeZ(u.left) # compute z for all descendants of u.left
5     maxVal = max(z[u.left], maxVal)
6   if u.right is not null:
7     computeZ(u.right) # computes z for all descendants of u.right
8     maxVal = max(z[u.right], maxVal)
9   z[u] = maxVal

```

We initially call `computeZ` on the root node of  $T$ . The algorithm takes  $O(1)$  time per node, which is  $O(n)$  overall<sup>a</sup>

<sup>a</sup>This algorithm can also be described as a modified version of the so-called *depth-first search* (DFS) graph traversal algorithm, which is different from BFS.

### Exercise 7.6

Your data center needs to run a number of jobs (compute requests) numbered  $1, 2, \dots, n$ . These are specified in a list of  $m$  tuples where  $(i, k)$  means that job  $i$  must be completed before job  $k$  can run. A given job may have multiple dependencies; for example, you might have constraints  $(1, 4), (2, 4), (3, 4)$  that all of jobs 1, 2, and 3 must be completed before 4 can run.

1. Describe an  $O(n + m)$  runtime algorithm that determines whether it is possible to execute all of the jobs, and if so, determines a valid order in which to execute the jobs one at a time. *Hint. How to relate SCCs to cycles?*
2. Suppose you have  $n$  identical servers (so that if there were no constraints you could simply run each job on a separate server). Suppose every job has the same runtime  $R$ . Describe an  $O(n + m)$  runtime algorithm to compute the total runtime that will be necessary to run all of the jobs in a valid order.

*Solution.* For this question we define a graph  $G = (V, E)$  where there is a vertex for every job  $1, \dots, n$  and an edge from  $i$  to  $k$  for every listed dependency (where  $k$  depends on  $i$ ).

1. We note that a sequence of jobs can be executed if and only if there is no circular dependency. In the language of graphs, this requires that  $G$  be free of cycles. To this end, it suffices to propose an algorithm that runs in  $\mathcal{O}(m + n)$ . We will use Kosaraju's SCC algorithm. We prove the following claim:

Any SCC with  $\geq 2$  vertices contain a cycle.

To see this, consider any distinct  $u, v$  in this SCC. Let  $p_{u,v}$  and  $p_{v,u}$  be the paths from  $u$  to  $v$  and backwards, respectively. Now concatenate the paths and get a walk that starts from  $u$  and ends at  $u$ . Note that each vertex appears at most once in  $p_{u,v}$  and in  $p_{v,u}$ , so in the combined walk, it appears at most twice. Consider the set of vertices that are revisited in this walk — clearly,  $u$  is one of them and is the latest one to be revisited. There must exist a vertex  $w$  that was the *first* to be revisited. Then, the section of the walk between the two visits of  $w$  form a cycle by definition: it starts from  $w$ , ends at  $w$ , and does not repeat any other vertices. This proves the claim. And to go back to our problem, the following are equivalent:

- (a) jobs can be executed
  - (b) no cycles in  $G$
  - (c) each SCC obtained from Kosaraju is a singleton
2. We first run the algorithm from part (a) to check if it is possible and to find a valid order of the jobs if so. Then define an array  $L$  of length  $n$ . We will compute  $L[k]$  as the length of the

longest dependency chain prior to  $k$ . Loop over the  $k$  jobs in topological order. For each, compute  $L[k] = 0$  if  $k$  has no dependencies, or  $L[k] = 1 + \max_{(i,k)} L[i]$  otherwise. Finally, return  $\max_k L[k]$ .

### Exercise 7.7

Let  $G = (V, E)$  be a directed graph with real-valued edge weights, where each vertex is colored in either **red** or **green**. Find the shortest/cheapest  $s - t$  walk such that, not counting  $s$ , the walk visits red vertices for an even number of times and green vertices at least thrice. (Duplicates allowed and will be counted more than once.)

*Solution.* Similar to the last problem in the previous recitation, the key insight lies in constructing a directed graph  $G' = (V', E')$  that captures some additional structures. Based on the constraints, as we walk along a path in  $G$ , there are two things we need to take care of:

- The number of (not necessarily distinct) red vertices we have walked past, and whether this number even or odd (this is called the *parity* of that number), and
- The number of (not necessarily distinct) distinct green vertices we have walked past.

To encode all of the information above, each vertex in  $G'$  will be represented by a “state”, or a tuple  $(v, p, g)$  where

- $v \in V$  corresponds to an original vertex in  $G$ ,
- $p \in \{0, 1\}$  (or “even”, “odd”) represents the parity of the count of red vertices (not necessarily distinct) visited so far, and
- $g \in \{0, 1, 2, 3+\}$  represents the number of times green vertices (not necessarily distinct) have been visited.

Now we will need to consider the conditions under which each of the tuple variable updates. For example, every time we visit a red vertex, the value  $p$  should alternate, and every time we visit a green vertex, the value  $g$  should increase until it becomes  $3+$ . Formally, the state transitions (i.e. edges in  $E'$ ) can be formulated as follows. For each edge  $(u, v)$  in the original graph  $G$ , depending on the colors of  $u$  and  $v$ , we add the following edges, all with the same weight as  $(u, v)$ , to  $E'$ :

( $v$  red) For every state  $(u, p, g)$  [a total of 8 such states because  $p \in \{0, 1\}$  and  $g \in \{0, 1, 2, 3+\}$ ], add an edge to the corresponding state  $(v, 1 - p, g)$ . In other words, we flip the parity because we visited one more red vertex, but this does not affect the value of  $g$ .

( $v$  green)

- For every state  $(u, p, g)$  with  $g \in \{0, 1, 2\}$ , add a (directed) edge to  $(v, p, g + 1)$  because our counter increases given  $v$  is green. (Define  $2 + 1$  to be “ $3+$ .”)
- For states of form  $(u, p, 3+)$ , add a (directed) edge to  $(v, p, 3+)$  because we still fall under the “ $g \geq 3$ ” category after visiting an additional green vertex.

All of our observations on the Recitation #2 graph modeling problem still hold: if we have a path in  $G'$ , we can uniquely recover a well-defined walk in  $G$ . Initially, we want to start from state  $(s, 0, 0)$  because we start from vertex  $s \in V$  and, per the problem, the starting point does not contribute to the red and green count. Our goal is to reach the state  $(t, 0, 3+)$ , which means (i) we arrive at  $t$ , and along the course we have (ii) visited an even number of red vertices and (iii) green vertices  $\geq 3$  times. This is exactly what we want.

How about the runtime? The construction of  $G'$  involves defining  $8|V|$  vertices since  $p$  has 2 possible values and  $g$  has 4, and we need to construct one state for each pair of  $p$  and  $g$ . Similarly, for each  $(u, v)$ , regardless of the color of  $v$ , in both cases we add a total of 8 edges. Therefore  $|E'| = 8|E|$ . Since  $G, G'$  are directed graphs with real-valued weights, we need to run Bellman-Ford, which takes  $\mathcal{O}(|V||E|)$ . Like shown before, other costs (e.g. the one to recover a walk in  $G$  from a path in  $G'$ ) are linear and hence dominated by the pathfinding runtime. So the final complexity is  $\mathcal{O}(|V||E|)$ .

**Exercise 7.8**

Let  $G = (V, E)$  be a weighted strongly connected directed graph with positive edge weights. Let  $v_0$  be a specific vertex. Describe an algorithm that computes the *cost* of the shortest walk between every pair of vertices of  $G$ , with the restriction that each of these walks must pass through  $v_0$  (that is, for every distinct pair  $u, v \in V$ , among all walks from  $u$  to  $v$  that pass through  $v_0$ , compute the cost of the shortest walk). Describe the algorithm, analyze its runtime complexity, and briefly explain (not a formal proof) why it is correct. Try to give an algorithm that runs in  $O(|E| \log(|V|) + |V|^2)$  time. As usual, you may use any algorithm as described in lecture without restating it or arguing for its correctness.

*Solution.* The high level idea is to decompose any qualifying  $u \rightarrow v$  walk into the combination of two paths  $u \rightarrow v_0 \rightarrow v$ , where we try to minimize the cost of both subpaths. It's easy to compute the minimum cost of  $v_0 \rightarrow v$  for all  $v$ : running Dijkstra once over the graph suffices. The first half,  $u \rightarrow v_0$ , is the nuisance since we need to calculate this quantity for every  $u \in V$ . Solution? Observe that the destination node  $v_0$  is fixed! We flip the direction, define a "reverse graph"  $G^{-1}$  where each edge carries its original weight but points in the other direction. Then, any cheapest  $v_0 \rightarrow u$  path in  $G^{-1}$  would correspond to the cheapest  $u \rightarrow v_0$  path in  $G$ , with matching total costs.

**Exercise 7.9**

Let  $G = (V, E)$  be a directed, weighted graph with  $|V| = n$  and  $|E| = O(n)$  (that is, the graph is sparse). Let  $s$  be a vertex in  $V$ . How quickly can the cost of the following shortest paths be computed under the given conditions? Just note the runtime and be prepared to explain. All of these can be solved using a single call to a shortest-path algorithm if provided the correct input graph (not necessarily the given one).

1. Compute the shortest path distance from some  $s$  to all other vertices in  $G$  under the condition that the weight of every edge is a positive integer  $\leq 10$ .
2. Compute the shortest path distance to a target  $t$  from all possible source vertices  $s$  in a graph with positive edge weights.

*Solution.* Listed.

1. Since all weights are integer and uniformly bounded, we convert  $G$  into an unweighted graph and apply BFS. Construct unweighted  $G' = (V', E')$  as follows: for each directed edge  $(u \rightarrow v \in E)$ , put a series of dummy nodes between  $u, v$  in  $G'$  so that the distance from  $u$  to  $v$  in  $G'$  is precisely the integer weight  $w(u, v)$  of  $u \rightarrow v$  in  $E$ . Now  $G$  has at most  $10n$  nodes and  $10n$  edges. So BFS runs in  $O(|V'| + |E'|) = O(n)$ .
2. Construct the reversed graph  $G^{-1}$  and run Dijkstra( $G^{-1}, t$ ). This finishes in  $\mathcal{O}((m+n) \log n) = O(n \log n)$  time since  $G$  is sparse.

**Exercise 7.10**

Let  $G = (V, E)$  be an undirected, weighted graph with non-negative edge weights. Let vertices  $s, t \in V$  be given. Describe an algorithm that efficiently solves the following questions.

1. Find the shortest/cheapest  $s - t$  walk with an even number of edges.
2. Find the shortest/cheapest  $u - v$  walk with a number of edges of form  $6k + 1, k \in \mathbb{N}$ .

*Solution.* Listed.

1. The key observation is that as we travel on  $G$ , the number of edges we have travelled along alternates between being odd and even. Furthermore, the very same vertex may correspond to both even and odd: for example if we walked along  $u \rightarrow v \rightarrow w \rightarrow u$ , then initially we travelled

for 0 edges, but upon return we travelled a total of 3 edges. We need a way to distinguish them. The solution? Duplicate each vertex into two categories: “odd” and “even.”

We construct a new graph  $G' = (V', E')$  by duplicating every vertex  $v \in V$ , labeling one of them as  $v_{\text{odd}}$  and the other  $v_{\text{even}}$ . For each edge  $(u, v) \in E$ , add two edges  $(u_{\text{odd}}, v_{\text{even}})$  and  $(u_{\text{even}}, v_{\text{odd}})$  to  $E'$ , both with the same as  $(u, v) \in E$ .

Clearly,  $|V'| = 2|V|$  and  $|E'| = 2|E|$ . What would edges look like in  $G'$ ? By construction, the two endpoints of an edge in  $G'$  have different subscripts, one with “odd,” the other “even.” This agrees with our previous observation on the original  $G$  that as we walk along the graph, the distance we have so far travelled alternates between even and odd. It follows that, starting from  $s_{\text{even}}$ , a vertex  $v_{\text{even}} \in V'$  (resp.  $v_{\text{odd}}$ ) is only reachable via even (resp. odd) number of edges.

On the other hand, also notice that there is a natural correspondence between edges in  $G'$  and  $G$ :  $(u_{\text{odd}}, v_{\text{even}}) \in E'$  corresponds to  $(u, v) \in E$ . This means a *path* in  $G'$  naturally corresponds to a walk in  $G$ , e.g.:

$$u_{\text{even}} \rightarrow v_{\text{odd}} \rightarrow w_{\text{even}} \rightarrow u_{\text{odd}} \rightarrow t_{\text{even}} \quad \text{corresponds to} \quad u \rightarrow v \rightarrow w \rightarrow u \rightarrow t.$$

Combining both observations above, there exists an  $s - t$  walk in  $G$  with an even number of edges if and only if there is a path in  $G'$  from  $s_{\text{even}}$  to  $t_{\text{even}}$ . The rest is simple: run a pathfinding algorithm on  $G'$ . The weights are non-negative, so we use Dijkstra’s algorithm.

Total runtime? Time to construct  $G'$  involves  $|V'| = 2|V|$  vertices and  $|E'| = 2|E|$  edges. This is dominated by running Dijkstra on  $G'$ , which takes  $O((|V'| + |E'|) \log |V'|) = O((|V| + |E|) \log |V|)$  time. Finally, transforming the path in  $G'$  back to a walk in  $G$  takes linear time w.r.t. the path length (one step for each edge), which is bounded by  $O(|E'|)$ . So overall most work is dominated by Dijkstra’s algorithm and the overall algorithm runs in  $O((|V| + |E|) \log |V|)$ .

2. Same idea but make 6 copies of the graph.

### Exercise 7.11

Suppose that in addition to having edge costs  $\{l_e : e \in E\}$ , a graph also has vertex costs  $\{c_v : v \in V\}$ . Now define the cost of a path to be the sum of its edge lengths, *plus* the costs of all vertices on the path. Give an efficient algorithm for finding the minimum cost path from  $s$  to  $t$ . You may assume edge costs and vertex costs are all nonnegative.

*Solution.* Using the generic approach, we can use  $\text{cost}_u(v) = \text{cost}(u) + w(u, v) + c_v$  to solve this problem. Alternatively, for each edge  $(u, v)$  we can update its weight to  $w(u, v) + c_v$  and run Dijkstra on this updated graph, which gives an equivalent mathematical formulation.

## 8 Dynamic Programming

Let's take a look at a motivating example.

### Example 8.1 (Computing Fibonacci Numbers)

To compute the  $N$ th Fibonacci number, we can use a recursive method.

#### Algorithm 11

Require:  $N$

```
function RECFIB( $N$ )
  if  $N = 0$  then
    return 0
  else if  $N = 1$  then
    return 1
  else
    return RecFib( $N - 1$ ) + RecFib( $N - 2$ )
  end if
end function
```

This is exponential, in fact  $O(\varphi^N)$  where  $\varphi$  is the golden ratio. The reason is that we are repeatedly computing the same subproblem (e.g.  $\text{RecFib}(N - 2)$  is computed twice), leading to inefficiency. It would be great if we could store these intermediate values rather than recomputing them. This introduces us to the concept of memoization.

### Definition 8.1 (Memoization)

**Memoization** refers to storing intermediate values for reuse rather than computing them again (e.g. in future recursive calls).

Therefore, the term **dynamic programming** just means *to deliberately evaluate and memoize in the correct order*.

### Algorithm 8.0 (Redursive Memoized Fibonacci)

This leads us to a memoized version of computing Fibonacci Numbers, which is linear runtime. In fact, we can have constant space complexity since we don't need more than the last 2 previous Fibonacci numbers to compute the next one.

**Algorithm 12** Memoized Fibonacci**Require:**  $N$ Initialize memo array  $F[0..N]$  with -1 $F[0] \leftarrow 0$  $F[1] \leftarrow 1$ **function** MEMFIB( $N$ )  **if**  $N < 0$  **then**    **return** 0  **else if**  $F[N] \neq -1$  **then**    **return**  $F[N]$   **else**     $F[N] \leftarrow \text{MEMFIB}(N - 1) + \text{MEMFIB}(N - 2)$     **return**  $F[N]$   **end if****end function**

The runtime is computed, by taking the number of distinct problems (i.e. the number of calls to MemFib with distinct inputs) multiplied by the time per subproblem (constant since lookup is constant and adding is constant). Note that this assumes that arbitrary arithmetic operations take constant time, but this is not true if we look at the bit complexity, which can scale quite fast as these numbers grow.

Note that this does not really explicitly show the order in which the memoized list is being filled. It is implicit but hard to see in the recursive calls. Therefore, it may help to write it iteratively.

**Algorithm 8.0 (Iterative Memoized Fibonacci)**

In here, we can explicitly see that the  $n$ th Fibonacci number is explicitly dependent on the  $n - 2$  and  $n - 1$ .

**Algorithm 13** Iterative Fibonacci**Require:**  $N$ Initialize array  $F[0..N]$  $F[0] \leftarrow 0$  $F[1] \leftarrow 1$ **for**  $i \leftarrow 2$  to  $N$  **do**   $F[i] \leftarrow F[i - 1] + F[i - 2]$ **end for****return**  $F[N]$ 

## 8.1 Longest Increasing Subsequence

**Definition 8.2 (Longest Increasing Subsequence)**

Given a sequence of numbers  $A = \{a_1, a_2, \dots, a_n\}$ , a **longest increasing subsequence** is a subsequence  $\{a_{i_1}, a_{i_2}, \dots, a_{i_k}\}$  of  $A$  such that:

1.  $1 \leq i_1 < i_2 < \dots < i_k \leq n$  (maintains original order)
2.  $a_{i_1} < a_{i_2} < \dots < a_{i_k}$  (strictly increasing)
3.  $k$  is maximized (longest such subsequence)

**Example 8.2**

For the sequence  $A = \{3, 10, 2, 1, 20, 4, 25\}$ :

- $\{3, 10, 20, 25\}$  is an increasing subsequence of length 4
- $\{2, 4, 25\}$  is an increasing subsequence of length 3
- $\{3, 10, 20, 25\}$  is a longest increasing subsequence as no increasing subsequence of length 5 or greater exists

For the actual problem of calculating the length of the LIS, dynamic programming gives us an efficient approach. First, let's do a brute force algorithm.

**Algorithm 8.0 (Recursive Brute Force LIS)**

At each step, we consider whether to include the current element in our subsequence. We can only include it if it's larger than the previous element we chose, maintaining the increasing property. We explore both possibilities (including and excluding) recursively to find the longest possible subsequence.

**Algorithm 14** Recursive Brute Force Longest Increasing Subsequence

```

Require: Array  $A[1..n]$ 
function LIS( $A, i, prev$ )                                ▷ $i$  is current position,  $prev$  is last element we took
  if  $i = n + 1$  then                                     ▷If we've processed all elements
    return 0                                              ▷Return 0 as we can't add more elements
  end if
  // First choice: skip current element
  skip  $\leftarrow$  LIS( $A, i + 1, prev$ )                       ▷Keep same prev, move to next element
  // Second choice: try to take current element
  take  $\leftarrow$  0                                          ▷Initialize take option to 0 in case we can't take it
  if  $A[i] > prev$  then                                     ▷Only if current element maintains increasing sequence
    take  $\leftarrow$  1 + LIS( $A, i + 1, A[i]$ )                 ▷Add 1 for taking current element
  end if                                                  ▷Recursively find best sequence starting at  $i+1$  with  $A[i]$  as previous
  // Return best option between taking and skipping
  return max(skip, take)                                  ▷Choose the better of our two options
end function
// Initial call with sentinel value to allow taking any first element
return LIS( $A, 1, -\infty$ )                                ▷Start at first element, no previous restrictions

```

The runtime can be used by the recurrence relation. At every call, we may at most have to compute 2 calls on the subarray not including the current element, and we compute the max of them which takes  $O(1)$ , so

$$T(N) = 2T(N - 1) + O(1) \implies T(N) = O(2^N) \quad (155)$$

which is not good.

Now let's move to our DP solution.

**Algorithm 8.0 (Dynamic Programming LIS)**

The key insight is that  $LIS[i]$  (the length of the LIS within the input array ending at  $i$ , inclusive) depends on all previous  $LIS[j]$  where  $j < i$  and  $A[j] < A[i]$ . For each position  $i$ , we can extend any previous increasing subsequence that ends with a smaller value. In other words, we are solving

$$LIS[i] = 1 + \max\{LIS[j] \mid j < i \text{ and } A[i] > A[j]\} \quad (156)$$

**Algorithm 15** Dynamic Programming Longest Increasing Subsequence

```

Require: Array  $A[1..n]$ 
function DPLIS( $A$ )
  // Initialize LIS array - each single element is an increasing sequence
  Initialize array  $LIS[1..n]$  with 1           ▷Base case: each element forms LIS of length 1
  for  $i \leftarrow 2$  to  $n$  do                 ▷Consider each element as end of sequence
    for  $j \leftarrow 1$  to  $i - 1$  do           ▷Look at all previous elements
      if  $A[i] > A[j]$  then                 ▷Can we extend sequence ending at  $j$ ?
         $LIS[i] \leftarrow \max(LIS[i], LIS[j] + 1)$    ▷Take best possible extension
      end if
    end for
  end for
  return  $LIS[-1]$                            ▷Find the maximum value in LIS array
end function

```

The runtime is  $O(n^2)$  since we have two nested loops, and the space complexity is  $O(n)$  since we store one value for each position in the array. Note that we could also have filled this DP array backwards by considering all arrays that start at  $A[i]$ .

**Example 8.3 (DPLIS for Small Array)**

For array  $A = [3, 1, 4, 1, 5]$ :

- Initially:  $LIS = [1, 1, 1, 1, 1]$
- After processing  $i = 2$ :  $LIS = [1, 1, 1, 1, 1]$
- After  $i = 3$ :  $LIS = [1, 1, 2, 1, 1]$  (4 can extend sequence from 3)
- After  $i = 4$ :  $LIS = [1, 1, 2, 2, 1]$
- After  $i = 5$ :  $LIS = [1, 1, 2, 2, 3]$  (5 can extend sequence from 4)

Final answer is 3, corresponding to subsequence  $[3, 4, 5]$

**8.2 0/1 Knapsack**

Another application of DP is in the following problem.

**Definition 8.3 (0/1 Knapsack)**

Given a knapsack with maximum weight capacity  $W$ , along with a set of  $n$  items, each with:

- Weight/Cost  $c_i$
- Value  $v_i$

You want to know the size of the subset of items that maximizes total value while keeping total weight/Cost  $\leq W$ . The constraint is that each item can be picked at most once (hence 0/1).

**Example 8.4**

For  $n = 3$  items and capacity  $W = 4$ :

- Item 1: ( $c_1 = 2, v_1 = 3$ )
- Item 2: ( $c_2 = 1, v_2 = 2$ )
- Item 3: ( $c_3 = 3, v_3 = 4$ )

Optimal solution: Take items 1 and 2

- Total weight:  $2 + 1 = 3 \leq 4$
- Total value:  $3 + 2 = 5$  (maximum possible)

The most natural way to approach this would be greedy, but this does not exactly work.

### Example 8.5 (Counter-Example for Greedy Knapsack)

Let's consider a knapsack with capacity  $W = 10$  and:

- Values  $V = [100, 48, 60, 11]$
- Weights  $C = [10, 6, 4, 1]$

Then the value/weight ratios would be

$$V/C = [10, 8, 15, 11] \quad (157)$$

and so we would choose to gain 60 for cost 4, then gain 11 for cost of 1. We do not have enough to buy any more and have a cost of 71, when we could have gotten a cost of 108 by buying 60 and 48 for a total of 10.

Just like as always, we just solve this using recursive brute force and then apply optimization with DP.

### Algorithm 8.0 (Recursive Brute Force Knapsack)

The key idea is that for each item, we have two choices: either include it (if we have enough capacity) or exclude it. We try both possibilities recursively to find the maximum value possible. In here,  $i$  represents the current item we're considering and  $r$  is the remaining weight we can still use.

---

#### Algorithm 16 Recursive Knapsack

---

**Require:** Values  $V[1..n]$ , Weights  $W[1..n]$ , Capacity  $C$

$V, W$

**function** KNAPSACK( $i, r$ )

**if**  $i = n + 1$  or  $r = 0$  **then** ▷Base case

**return** 0 ▷Either we've considered all items or filled the knapsack

**end if** ▷No more value can be added

    skip  $\leftarrow$  KNAPSACK( $i + 1, r$ ) ▷1st Op: Skip current item and maintain same  $r$

    take  $\leftarrow$  0 ▷2nd Op: Try to include curr item

**if**  $W[i] \leq r$  **then** ▷Only try taking if item's weight fits in remaining  $r$

        take  $\leftarrow V[i] +$  KNAPSACK( $i + 1, r - W[i]$ ) ▷Add current item's value + best value from remaining items

**end if** ▷Subtract current item's weight from remaining  $r$

**return** max(take, skip) ▷Return best possible value between two choices

**end function**

// Start considering from first item with full  $r$

**return** KNAPSACK(1,  $C$ )

---

Now let's apply memoization.

### Algorithm 8.0 (Dynamic Programming Knapsack)

The key insight is that  $K[i, r]$  (best value possible using items up to  $i$  exclusive with remaining capacity  $r$ ) can be built from  $K[i - 1, r]$  and  $K[i - 1, r - W[i]]$  using the formula

$$K[i, r] = \begin{cases} K[i - 1, r] & \text{if } W[i] > r \text{ (can't take item } i) \\ \max(K[i - 1, r], V[i] + K[i - 1, r - W[i]]) & \text{if } W[i] \leq r \text{ (can take item } i) \end{cases} \quad (158)$$

In here,  $i$  represents the items 1.. $i$  we're considering and  $r$  represents the remaining capacity.

**Algorithm 17** Dynamic Programming Knapsack**Require:** Values  $V[1..n]$ , Weights  $W[1..n]$ , Capacity  $C$  $V, W$ **function** DPKNAPSACK( $C$ )Create table  $K[0..n, 0..C]$  $\triangleright K[i,r] = \text{max value using items } V[:i] \text{ with remaining } r$ 

Initialize all entries to 0

**for**  $i \leftarrow 1$  to  $n$  **do** $\triangleright$  Consider each item**for**  $r \leftarrow 0$  to  $C$  **do** $\triangleright$  Consider each possible remaining capacity $K[i, r] \leftarrow K[i - 1, r]$  $\triangleright$  Default: inherit value from excluding item  $i$ **if**  $r \geq W[i]$  **then** $\triangleright$  If current item fits in remaining capacitytake  $\leftarrow V[i] + K[i - 1, r - W[i]]$  $\triangleright$  Value of item  $i$  + best value with remaining  $r$  $K[i, r] \leftarrow \max(K[i, r], \text{take})$  $\triangleright$  Take better of including or excluding**end if****end for****end for****return**  $K[n, C]$  $\triangleright$  Best value possible using all items**end function**

The memory complexity is obviously  $\Theta(nC)$ . The number of subproblems is  $nC$ , and the processing for each step is constant time (possibly addition and max), so  $O(1)$ . Therefore the total runtime is  $O(nC)$  also. Note that if we compare this in terms of the bit runtime, then this is  $O(n \log_2 C)$ , which is pseudopolynomial since  $C$  is described by  $\log_2 C$  bits. However, the  $n$  will scale linearly since it is the size of the array and not the size of each integer in  $V, W$ .

Note that if  $C$  can be very big, and this can be problematic.

### 8.3 Line Breaking

#### Definition 8.4 (Line Breaking)

Line breaking is used whenever you compile a tex document. Given

- a sequence of words  $w_1, w_2, \dots, w_n$  where  $w_i$  has length  $l_i$
- a maximum line length  $L$
- each line must contain whole words in order, separated by spaces

Our goal is to break words into lines to minimize the sum of squares of empty spaces at the end of each line, i.e. our cost function for a sequence of words  $W[i : j + 1]$  is

$$\left( L - \sum_{k=i}^j w_k \right)^2 \quad (159)$$

If we used the absolute value, there exists a greedy solution.

#### Example 8.6 (Line Breaking Example)

Given  $L = 20$  and  $W = [12, 8, 9]$  (note that spaces won't count in length in this problem), we have 3 possible arrangements.

1. Option 1: First two words on first line
  - Line 1:  $[12 + 8 = 20]$  (0 spaces remain)
  - Line 2:  $[9]$  (11 spaces remain)
  - Total cost =  $0^2 + 11^2 = 121$

2. Option 2: Words one per line
  - Line 1: [12] (8 spaces remain)
  - Line 2: [8] (12 spaces remain)
  - Line 3: [9] (11 spaces remain)
  - Total cost =  $8^2 + 12^2 + 11^2 = 64 + 144 + 121 = 329$
3. Option 3: Word 2 and 3 together
  - Line 1: [12] (8 spaces remain)
  - Line 2: [8 + 9 = 17] (3 spaces remain)
  - Total cost =  $8^2 + 3^2 = 64 + 9 = 73$

Therefore, Option 3 is optimal with cost 73. This also demonstrates that the greedy strategy, which gives Option 1, will not work.

We start off with recursive brute force. Given any word  $w_i$ , we can either end the line there  $w_i$  or add another word  $w_i w_{i+1}$ .

### Algorithm 8.0 (Recursive Brute Force Line Breaking)

The key idea is at each position  $i$ , we try placing different numbers of words on the current line and recursively solve for the rest. For each word  $i$ , we try all possible ways to break the line starting at word  $i$ . Let  $MinCost(i)$  be the minimum cost to arrange words  $[i..n]$ . Then:

$$MinCost(i) = \begin{cases} 0 & \text{if } i > n \\ \min_{i \leq j \leq n} \{ (L - \sum_{k=i}^j W[k])^2 + MinCost(j+1) \} & \text{if else} \end{cases} \quad (160)$$

where  $(L - \sum_{k=i}^j W[k])^2$  is the cost to put the words  $i..j$  on a new line and then ending. So whenever we add the new  $i$ th word at the end of the line, we are looking at all words  $j$  at which we can break the line, and taking the minimum cost given this line break. The line break from  $j+1$  should be computed as well (this is what we will store in our DP array later).

### Algorithm 18 Recursive Line Breaking

**Require:** Word lengths  $W[1..n]$ , Line length  $L$

W

```

function MINCOST( $i$ )                                ▷Returns min cost for words[ $i..n$ ]
  if  $i = n + 1$  then                                  ▷Base case: no words left
    return 0
  end if
  min_cost  $\leftarrow \infty$ 
  lineLen  $\leftarrow 0$ 
  for  $j \leftarrow i$  to  $n$  do                          ▷Try placing words  $i$  through  $j$  on current line
    lineLen  $\leftarrow$  lineLen +  $W[j]$ 
    if lineLen  $\leq L$  then                               ▷If these words fit on the line
      spaces  $\leftarrow L -$  lineLen                       ▷Extra spaces at end of line
      cost  $\leftarrow$  spaces2 + MINCOST( $j + 1$ )           ▷Cost of this line + rest
      min_cost  $\leftarrow$  min(min_cost, cost)
    end if
  end for
  return min_cost
end function
return MINCOST(1)                                    ▷Start with first word

```

**Example 8.7 (Recursive Brute Force Line Breaking)**

For example, with  $L = 20$  and  $W = [12, 8, 9]$ :

- At  $i = 1$ : Try
  - 12 alone (8 spaces) + solve for [8,9]
  - 12,8 together (0 spaces) + solve for [9]
- At  $i = 2$ : Try
  - 8 alone (12 spaces) + solve for [9]
  - 8,9 together (3 spaces) + solve for []
- At  $i = 3$ : Try
  - 9 alone (11 spaces) + solve for []

**Algorithm 8.0 (Dynamic Programming Line Breaking)**

The key insight is that  $DP[i]$  represents the minimum cost of optimally arranging words  $[i..n]$ . For each word  $i$ , we try placing words  $[i..j]$  on a line and add the cost of optimally arranging the remaining words  $[j + 1..n]$ . We do the same logic but rather than computing it we just retrieve it from the DP array.

$$DP[i] = \begin{cases} 0 & \text{if } i > n \\ \min_{i \leq j \leq n} \{(L - \sum_{k=i}^j W[k])^2 + DP[j + 1]\} & \text{if else} \end{cases} \quad (161)$$

**Algorithm 19** Dynamic Programming Line Breaking

**Require:** Word lengths  $W[1..n]$ , Line length  $L$

W

**function** LINEBREAK( $L$ )

  Create array  $DP[0..n]$

▷ $DP[i]$  = min cost for words $[i..n]$

  Initialize all entries to  $\infty$

$DP[n + 1] \leftarrow 0$

▷Base case: no words left

**for**  $i \leftarrow n$  **downto** 1 **do**

▷Consider each starting word

    lineLen  $\leftarrow 0$

**for**  $j \leftarrow i$  **to**  $n$  **do**

▷Try placing words  $i$  through  $j$  on a line

      lineLen  $\leftarrow$  lineLen +  $W[j]$

**if** lineLen  $\leq L$  **then**

▷If these words fit on the line

        spaces  $\leftarrow L -$  lineLen

▷Extra spaces at end

        cost  $\leftarrow$  spaces<sup>2</sup> +  $DP[j + 1]$

▷Cost of this line + rest

$DP[i] \leftarrow \min(DP[i], \text{cost})$

▷Update if better

**end if**

**end for**

**end for**

**return**  $DP[1]$

▷Cost of optimally arranging all words

**end function**

The memory complexity is clearly  $O(n)$ . To add each element  $i$ , we must iterate over all the possible  $j$ 's, making this  $O(n^2)$  total iterations. However, computing the cost is also  $O(n)$ , making the total runtime  $O(n^3)$ . However, if we also store another DP array **sums**, which can be computed in linear time and stores

$$\text{sums}[i] = \sum_{k=i}^n w_k \implies \sum_{k=i}^j = \sum_{k=i}^n w_k - \sum_{k=j+1}^n w_k = \text{sums}[i] - \text{sums}[j+1] \quad (162)$$

which can be accessed and computed in  $O(1)$  time, bringing us down to  $O(n^2)$ .

**Example 8.8 (DP Line Breaking)**

For example, with  $L = 20$  and  $W = [12, 8, 9]$ :

- $DP[4] = 0$  (base case)
- $DP[3] = 11^2 = 121$  (only option for last word)
- $DP[2] = \min(12^2 + 121, 3^2) = \min(265, 9) = 9$  (alone or with word 3)
- $DP[1] = \min(8^2 + 9, 0^2 + 121) = \min(73, 121) = 73$  (alone or with word 2)

**8.4 Bellman Ford Revisited**

Recall the Bellman equations that we must solve using DP. That is, given some  $s \in V$ ,

$$d[v] = \min_w \{d[w] + l_{wv}\} \quad (163)$$

with  $d[s] = 0$ . Note that the problem was not well defined if there are negative cycles in the graph, since we can just loop an infinite number of times. However, we can modify the bellman equations to get a better sense.

**Theorem 8.1 (Modified Bellman Equations)**

For paths of length at most  $i$  edges, the Bellman equations become:

$$d(v, i) = \begin{cases} 0 & \text{if } v = s \\ \min\{d(v, i - 1), \min_{(u,v) \in E} \{d(u, i - 1) + w_{uv}\}\} & \text{otherwise} \end{cases} \quad (164)$$

where  $d(v, i)$  represents the shortest path from source  $s$  to vertex  $v$  using at most  $i$  edges, and  $w_{uv}$  represents the weight of edge  $(u, v)$ . Note that the inner minimum takes the minimum over all paths with the final edge connecting from some other node  $u$  to target  $v$ , and the outer minimum compares this minimum path to what we already have to see if it's an improvement.

This indicates that we should use a 2D DP array to memoize. This allows you to have a more flexible representation in case there are negative cycles since we are also limiting the number of edges a path could have.

**Algorithm 8.0 (2D DP Bellman-Ford)**

The implementation of the modified equations gives us the following algorithm.

**Require:** Nodes  $V$ , Edges  $E$ , source  $s$

```

1:  $d \leftarrow$  2D array of size  $|V| \times |V|$  initialized to  $\infty$ 
2:  $d[s, 0] \leftarrow 0$  ▷Base case: Can reach source with 0 edges
3: for  $i = 1, \dots, n - 1$  do
4:   for  $v \in V$  do
5:      $d[v, i] \leftarrow d[v, i - 1]$  ▷Keep best path seen so far
6:     for  $(u, v) \in E$  do
7:        $d[v, i] \leftarrow \min(d[v, i], d[u, i - 1] + l_{uv})$ 
8:     end for
9:   end for
10: end for

```

Note that this algorithm still has time complexity  $O(nm)$  because the outer loop runs  $n - 1$  times and for each iteration, we examine each edge once. The space complexity is  $O(n^2)$ , and finally, note the important properties.

1. *Monotonicity*: For all vertices  $v$  and indices  $i$ :

$$d(v, i) \leq d(v, i - 1) \tag{165}$$

This is because any path using  $\leq (i - 1)$  edges is also a valid path using  $\leq i$  edges.

2. *Convergence*: The algorithm will stabilize after at most  $n - 1$  iterations since:

- Any shortest path without negative cycles can use at most  $n - 1$  edges
- Therefore,  $d(v, n - 1) = d(v, n)$  for all  $v$  if no negative cycles exist

3. *Negative Cycle Detection*: A negative cycle exists if and only if:

$$\exists v \in V : d(v, n) < d(v, n - 1) \tag{166}$$

This is because any improvement after  $n - 1$  edges must use a negative cycle.

## 9 Probabilistic Algorithms

### 9.1 Primality Testing

## 10 Efficiency

### 10.1 Classification of Decision Problems

We have talked about *optimization problems* that choose the best solution from a class of solutions. Now we will talk about *decision problems*, which seek to prove or disprove the existence of a solution satisfying a certain property.

#### Lemma 10.1 (Conversion between Optimization and Decision Problems)

It turns out we can convert one into the other easily by rephrasing the problem. The following conversion will be used frequently.

1. Given a problem  $P$ , we want to find a solution that minimizes some variable  $K$ .
2. Given a problem  $P$  and some constant  $K'$ , does there exist a solution that is less than  $K'$ ?

Voila.

Now that this is established, we can freely consider the classes  $P$  and  $NP$  of all decision problems and classify them. There are equivalent definitions for optimization problems, but it is more popular to pose these classes as decision problems.

#### Definition 10.1 ( $P$ )

$P$  (Polynomial Time) is the set of all decision problems that can be solved by polynomial-time algorithms.

#### Definition 10.2 ( $NP$ )

$NP$  (Nondeterministic Polynomial Time) is the set of all decision problems for which if it returns 1 (i.e. a solution exists), this can be *verified* in polynomial time.<sup>a</sup>

<sup>a</sup>The fact that a *proposed* solution can be verified is important! Proving or disproving a proposed solution is much easier than proving the nonexistence of a solution.

The other way around  $NP \subset P$  is an unsolved millenium conjecture. It attempts to answer what the runtime difference or difficulty is between solving and verifying a problem? The conjecture states that solving is exponentially harder than verifying.

#### Theorem 10.2

$$P \subset NP$$

*Proof.* Given a problem  $\pi$  with a proposed solution  $p$ , we can run  $p$  in polynomial time to verify it.

Colloquially, the set of problems which are at least as hard as  $NP$  is called *NP-hard*, which can be defined for both optimization and decision problems. These are the absolute hardest problems. The formal definition of NP-Hard problems is shown below.

#### Definition 10.3 (NP-Hard)

A (decision or optimization) problem  $\pi$  is NP-hard iff the existence of a polynomial time algorithm for  $\pi$  implies  $P = NP$ .

**Definition 10.4 (NP-Complete)**

The intersection of NP-hard and NP is **NP-complete**, which can be thought of as the hardest problems existing in NP. The worst case runtime complexity of an NP-complete problem is exponential.

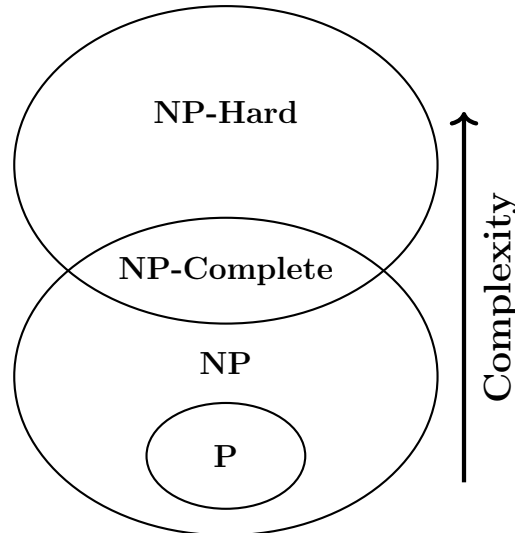

Figure 52: Diagram of the 4 classes. The complexity rises as we go up.

## 10.2 Proving NP-Hardness

To show that a problem is in P, all we have to do is find a polynomial time algorithm, which is what we've been doing this entire course. To show whether a problem is NP, we should show that it is verifiable in polynomial time, which we have also done so far. Proving NP-hardness (which then allows us to prove NP-completeness) is a bit more tricky. The pattern is always three things.

1. *Reduction.* Describe a polynomial time algorithm  $f$  to transform an *arbitrary instance*  $x$  of a problem  $\beta$  into a *special instance*  $y = f(x)$  of a problem  $\pi$ .
2. *Equivalence.* Prove that if arbitrary  $x$  is a true instance of  $\pi$ , then  $y$  is a true instance of  $\beta$ .
3. *Equivalence.* Prove that if arbitrary  $y$  is a true instance of  $\beta$ , then  $x$  is a true instance of  $\pi$ .<sup>12</sup>

**Definition 10.5 (Reduction)**

In other words, to prove a problem  $\pi$  is NP-hard, reduce<sup>a</sup> a known NP-hard problem  $\beta$  to  $\pi$  in polynomial time (not the other way around!). If this reduction is possible, then we claim that  $\pi$  must be at least as hard as  $\beta$ :  $\beta \leq_p \pi$ .

1. Assume that we can solve  $\pi$  in polytime.
2. Then we can solve  $\beta$  in polytime by first converting any instance of  $\beta$  to  $\pi$  in polytime, and then polytime solving  $\pi$ .<sup>b</sup>
3. Therefore,  $\pi \in P \implies \beta \in P$ .

But since we already know  $\beta$  is NP-hard, this creates a contradiction. Therefore,  $\pi \notin P$ .

<sup>a</sup>The fact that we say reduce here is misleading, since we are showing that the reduction is at least as hard as the original.

<sup>b</sup>In other words, there exists an injective (but not necessarily surjective) mapping from the set of solutions of  $\pi$  to the set of solutions of  $\beta$ .

<sup>12</sup>This is the hard part.

The reduction serves to compare the two problems, and the equivalence then serves to compare the set of solutions to these two problems.

### Definition 10.6 (Equivalence of Solutions)

The next step is to show two things:

1. A solution to  $\pi$  implies a solution to  $\beta$ , and
2. A solution to  $\beta$  implies a solution to  $\pi$ .

As a general overview of popular problems and their relation to each other, we'll mention this now.

### Theorem 10.3 (Reduction Tree of NP-Hard Problems)

For convenience.

1. 3SAT is NP-hard by Cook-Levin
2. CircuitSAT is NP-hard by reducing from 3SAT
3. Max Independent Set is NP-hard by reducing from 3SAT
4. Min Vertex Cover is NP-hard by reducing from MIS
5. Max Clique is NP-hard by reducing from MIS
6. Hamiltonian Path is NP-hard
7. Hamiltonian Cycle is NP-hard by reducing from MVC, 3SAT, or Hamiltonian Path
8. Graph Coloring is NP-hard by reducing from 3SAT
9. Subset Sum is NP-hard by reducing from MVC
10. Planar CircuitSAT is NP-hard by reducing from CircuitSAT
11. Partitioning<sup>a</sup> is NP-hard by reducing from Subset Sum.
12. Set Cover<sup>b</sup> is NP-hard.
13. Longest Path is NP-hard.
14. MaxCut<sup>c</sup> is NP-hard.

<sup>a</sup>Given a set  $S$  of  $n$  integers, are there disjoint subsets  $A, B$  s.t. their sums are equal?

<sup>b</sup>Given a collection of sets  $S$ , find the smallest sub-collection of sets that contains all the elements in  $\cup S$ .

<sup>c</sup>Find the max cut of a graph.

## 10.3 Logic and Satisfiability

### Definition 10.7 (CircuitSAT)

Consider a black box circuit  $f$ , with input  $\mathbf{x} \in \{0, 1\}^n$ . We want to answer the question of whether there exists some  $\mathbf{x}$  s.t.  $f(\mathbf{x}) = 1$ , i.e. whether the circuit is **satisfiable** (i.e. outputs a 1 bit).

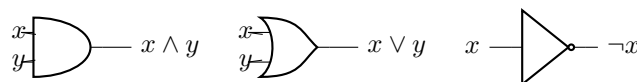
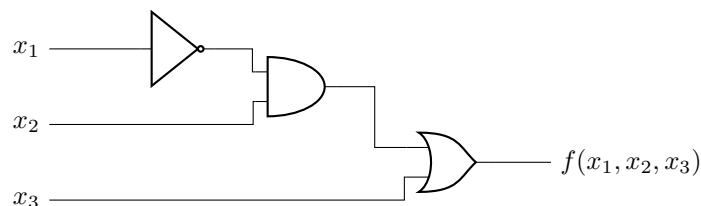

Figure 53: Some random circuit where  $n = 5$ .

The obvious way is to brute force is to check all  $2^n$  combinations, and this is the only way since this is black-box. However, even if we knew the circuit itself, the amount of computations that we need to solve this is conjectured to be still  $O(2^n)$ , though we may be able to cleverly shave off some calculations here and there.<sup>a</sup>

<sup>a</sup>It is not proven that there exists no exponential algorithm.

### Definition 10.8 (3SAT)

Given a boolean formula  $\phi$  of  $N$  variables where each **clause** contains exactly 3 literals, determine if there exists a satisfying assignment to the variables that makes  $\phi$  true. Formally:

$$\begin{aligned}\phi &= C_1 \wedge C_2 \wedge \cdots \wedge C_m \\ C_i &= (l_{i1} \vee l_{i2} \vee l_{i3}) \\ l_{ij} &\in \{x_k, \neg x_k\} \text{ for some } k \in \{1, \dots, n\}\end{aligned}$$

where  $x_k$  are boolean variables and  $\neg x_k$  their negations. For example:

$$\phi = (x_1 \vee \neg x_2 \vee x_3) \wedge (\neg x_1 \vee x_2 \vee x_4) \wedge (x_2 \vee \neg x_3 \vee \neg x_4)$$

Like CircuitSAT, this problem is also believed to require  $O(2^n)$  time, and in fact these problems are polynomially reducible to each other ( $\text{CircuitSAT} \leq_p \text{3SAT}$  and  $\text{3SAT} \leq_p \text{CircuitSAT}$ ). The key difference is that 3SAT has a very specific structure that makes it easier to analyze and reduce other problems to, making it a canonical NP-complete problem.<sup>a</sup>

<sup>a</sup>The restriction to exactly 3 literals per clause is not arbitrary - 2SAT is solvable in polynomial time, while 3SAT is NP-complete.

In fact, there is a polynomial time algorithm to translate between 3SAT and CircuitSAT, so the two are theoretically equivalent.

### Theorem 10.4 (P, NP Classification of SAT)

For CircuitSAT,

$$\text{CircuitSAT} \notin P, \text{CircuitSAT} \in NP \quad (167)$$

That is, it cannot be solved in polynomial time, but given a solution circuit and a satisfying assignment, the assignment can be verified in polynomial time. For 3SAT,

$$\text{3SAT} \notin P, \text{3SAT} \in NP \quad (168)$$

That is, it cannot be solved in polynomial time, but given a solution formula and a satisfying assignment, the assignment can be verified in  $O(N^3)$  time ( $N^3$  comes from the size of the expression).

### Theorem 10.5 (Cook-Levin)

3SAT is NP-complete.

*Proof.* The proof is extremely long, and we use this as the initial point from which we start proving NP-hardness of other problems using reduction.

For example, to prove that CircuitSAT is NP-hard, we should reduce 3-SAT to CircuitSAT in polynomial time and then we are done. Reduction is quite complicated, so we omit this for now.

## 10.4 Graph Problems

### 10.4.1 Maximum Independent Set

#### Definition 10.9 (MIS)

Given an undirected graph  $G(V, E)$ , an **independent set** is a subset  $S \subseteq V$  such that no two vertices in  $S$  are connected by an edge in  $E$ . The **maximum independent set** problem asks

1. Given  $G$ , find an independent set of maximum cardinality.
2. Given  $G$  and constant  $K$ , does there exist an independent set of size  $\geq K$ ?

#### Theorem 10.6 (Maximum Independent Set (MIS))

MIS is NP-hard.

*Proof.* We prove NP-hardness by reducing from 3SAT, which is more structured than CircuitSAT. Given a 3SAT instance  $\phi$ , we construct a graph  $G$  such that  $\phi$  is satisfiable if and only if  $G$  has an independent set of size  $m$ , where  $m$  is the number of clauses in  $\phi$ . The reduction works as follows: For a 3SAT formula  $\phi = C_1 \wedge C_2 \wedge \dots \wedge C_m$  where each clause  $C_i = (l_{i1} \vee l_{i2} \vee l_{i3})$ , construct graph  $G(V, E)$ :

1. For each clause  $C_i$ , create a **clause gadget**: a triangle with vertices labeled  $l_{i1}$ ,  $l_{i2}$ , and  $l_{i3}$  with undirected edges between them.
2. Add **consistency edges**: for any two literals  $l_{ij}$  and  $l_{k\ell}$  from different triangles, add an edge if they are complementary (i.e., one is  $x$  and the other is  $\neg x$ )

This reduction has the following properties:

- Each triangle forces us to choose at most one literal from each clause
- Consistency edges ensure we can't choose contradictory literals
- Choosing  $m$  vertices (one per triangle) corresponds to making each clause true

For equivalence, it turns out that  $\phi$  is satisfiable iff the size of the IS in  $G$  is exactly the number of clauses in  $\phi$ .

- ( $\Rightarrow$ ) If  $\phi$  is satisfiable, choose one true literal from each clause to form an independent set of size  $m$
- ( $\Leftarrow$ ) If  $G$  has an independent set of size  $m$ , it must contain exactly one vertex per triangle (by pigeonhole principle), giving us a valid satisfying assignment

Therefore, now that we have established the reduction, since 3SAT is NP-complete and we have a polynomial-time reduction to MIS, MIS is NP-hard.

#### Example 10.1 (3SAT Reduction of MIS)

Consider the 3SAT formula

$$\phi = (a \vee b \vee c) \wedge (b \vee \neg c \vee \neg d) \wedge (\neg a \vee c \vee d) \wedge (a \vee \neg b \vee \neg d) \quad (169)$$

Following our reduction, we construct graph  $G$  as follows:

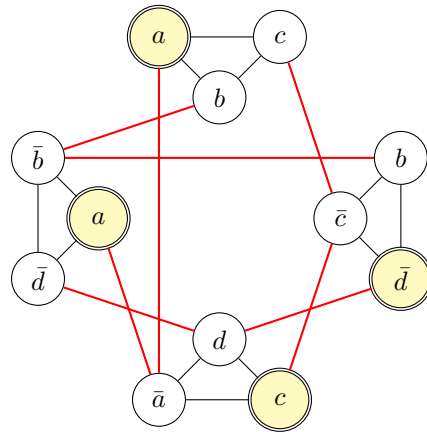

Figure 54: Reduction graph from 3SAT to MIS.

The graph contains:

1. Four triangles, one for each clause of  $\phi$
2. Red edges connecting complementary literals (e.g.,  $b$  with  $\bar{b}$ )
3. A maximum independent set highlighted in yellow ( $\{a, d\}$ ) of size 4

This independent set corresponds to the satisfying assignment  $(a, b, c, d) = (1, *, 1, 0)$ .

- $(a \vee b \vee c)$  is satisfied by  $a = 1$
- $(b \vee \neg c \vee \neg d)$  is satisfied by  $d = 0$ .
- $(\neg a \vee c \vee d)$  is satisfied by  $c = 1$ .
- $(a \vee \neg b \vee \neg d)$  is satisfied by  $a = 1$ .

To demonstrate the proof, we assume that this MIS can be solved in polynomial time, so  $MIS \in P$ . But since  $3SAT \leq_p MIS$ , this means that  $3SAT \in P$ , which is a contradiction since  $3SAT \in NP - hard$ .

#### 10.4.2 Minimum Vertex Cover

##### Definition 10.10 (Min Vertex Cover)

Given an undirected graph  $G(V, E)$ , a **vertex cover** is a subset  $S \subset V$  where for all  $(u, v) \in E$ , either  $u \in S$  or  $v \in S$  (or both). The **minimum vertex cover** problem asks

1. Given  $G$ , find a vertex cover of minimum cardinality.
2. Given  $G$  and constant  $K$ , does there exist a vertex cover of size  $\leq K$ ?

##### Theorem 10.7 (MVC)

MVC is NP-hard.

*Proof. Reduction from MIS.* Recall that an independent set is a subset  $S \subset V$  s.t. for all  $(u, v) \in E$ ,  $u \in S$  or  $v \in S$  (but not both). By definition, we can see that  $u \in S \iff u \notin V \setminus S$ , and so IS and VCs are related in the following way:

$$S \subset V \text{ is a VC} \iff \forall (u, v) \in E, u \in S \text{ or } v \in S \text{ or both} \quad (170)$$

$$\iff \forall (u, v) \in E, u \notin S \setminus V \text{ or } v \notin S \setminus V \text{ or both} \quad (171)$$

$$\iff V \setminus S \text{ is an IS} \quad (172)$$

Therefore, if  $S$  has size  $K$ , then  $V \setminus S$  will have size  $N - K$ . We assume that a polytime algorithm exists for MVC, so on input  $G(V, E)$ , we calculate the MVC, call it  $M$ , and then we return the corresponding

MIS  $S = V \setminus M$ .

*Equivalence.*

1. ( $\Rightarrow$ ) Assuming we have the solution  $|S|$  for MVC, we can return true iff  $|V| - |S| \geq K$ .
2. ( $\Leftarrow$ ) Assuming we have the solution  $|S|$  for MIS, we can return true iff  $|V| - |S| \leq K$ .

But this would imply that there exists such a polytime algorithm, implying that  $P = NP$ , and therefore MVC must be NP-hard by definition.

#### Example 10.2 (Reduction from Independent Set to Vertex Cover)

Just take the complement.

### 10.4.3 Maximum Clique

#### Definition 10.11 (Max Clique)

Given an undirected graph  $G(V, E)$ , a **clique** is a subset of vertices  $S \subset V$  s.t. there is an edge between each pair in  $S$ , i.e. a *complete subgraph*. The **maximum clique** problem asks

1. Given  $G$ , find the clique of maximum cardinality.
2. Given  $G$  and constant  $K$ , does there exist a vertex cover of size  $\geq K$ ?

#### Theorem 10.8 (MC)

Finding the max clique is NP-hard.

*Proof. Reduction from MIS.* Observe that

Let's define the **edge-complement** of a graph  $G$  as  $\bar{G} = (V, \bar{E})$  where  $\bar{E}$  is the set of edges not in  $G$ . Then, note that

$$S \subset V \text{ is an IS of } G \iff \forall u, v \in S, (u, v) \notin E \quad (173)$$

$$\iff \forall u, v \in S, (u, v) \in \bar{E} \quad (174)$$

$$\iff S \text{ is a clique of } \bar{G} \quad (175)$$

Therefore, we can reduce this from MIS by taking input  $G$ , getting  $\bar{G}$  in  $O(N + M)$  time, solving the MIS of  $\bar{G}$ , and returning the size of the max clique of  $\bar{G}$  in our assumed polytime algorithm. Therefore, MC is NP-hard. In fact, we have already proved the equivalence at the same time due to the iff conditions, but we state it explicitly for completeness.

*Equivalence.*

1. ( $\Rightarrow$ ) Assuming we have the MIS solution  $S \subset \bar{G}$ , then  $S$  is the max clique of  $\bar{G}$ .
2. ( $\Leftarrow$ ) Assuming we have the max clique solution  $S \subset \bar{G}$ , then  $S$  is the MIS of  $\bar{G}$ .

#### Example 10.3 (Reduction of Independent Set to Clique)

Just take the edge complement.

## 10.4.4 Hamiltonian Paths

**Definition 10.12 (Hamiltonian Path)**

A **Hamiltonian path** in a directed graph  $G$  is a path that visits every vertex exactly once.

**Theorem 10.9**

Finding the existence of a Hamiltonian cycle of a graph  $G$  is NP-hard.

**Definition 10.13 (Hamiltonian Cycle)**

A **Hamiltonian cycle** in a directed graph  $G$  is a cycle that visits every vertex exactly once.

**Theorem 10.10**

Finding the existence of a Hamiltonian cycle of a graph  $G$  is NP-hard.

*Proof. Reduction from VC.* Given an undirected graph  $G(V, E)$  and integer  $K$ , we want to construct a directed graph  $H(V', E')$ , such that  $H$  has a Hamiltonian cycle iff  $G$  has a vertex cover of size  $K$ . We construct  $H$  in the following.

1. For each undirected edge  $(u, v) \in E$ , the directed graph  $H$  contains an *edge gadget* containing 4 vertices

$$(u, v, \text{in}), (u, v, \text{out}), (v, u, \text{in}), (v, u, \text{out}) \quad (176)$$

and 6 directed edges

$$\begin{array}{lll} (u, v, \text{in}) \rightarrow (u, v, \text{out}) & (u, v, \text{in}) \rightarrow (v, u, \text{in}) & (v, u, \text{in}) \rightarrow (u, v, \text{in}) \\ (v, u, \text{in}) \rightarrow (v, u, \text{out}) & (u, v, \text{out}) \rightarrow (v, u, \text{out}) & (v, u, \text{out}) \rightarrow (u, v, \text{out}) \end{array}$$

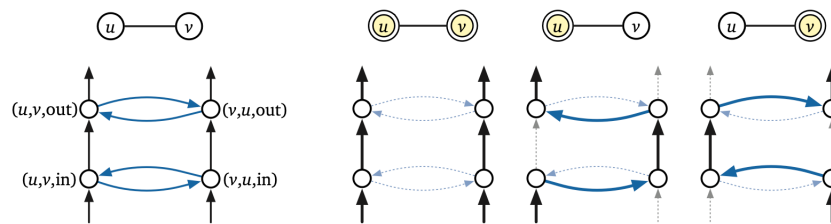

Figure 55: An edge gadget and its only possible interactions with a Hamiltonian cycle. Any Hamiltonian cycle in  $H$  must pass through an edge gadget in one of 3 ways: straight through on both sides, or with a detour from one side to the other and back. These options will correspond to both  $u$  and  $v$ , only  $u$ , or only  $v$  belonging in the vertex cover.

2. For each vertex  $u \in V$ , all the edge gadgets for incident edges  $(u, v)$  are connected in  $H$  into a single directed path, called a *vertex chain*. Specifically, suppose vertex  $u$  has  $d$  neighbors  $v_1, \dots, v_d$ . Then  $H$  has  $d - 1$  additional edges  $(u, v_i, \text{out}) \rightarrow (u, v_{i+1}, \text{in})$  for each  $i = 1, \dots, d - 1$ .
3. Finally,  $H$  also contains  $k$  *cover vertices*  $x_1, \dots, x_k$ . Each cover vertex has a directed edge to the first vertex in the vertex chain, and a directed edge from the last vertex in each vertex chain.

*Equivalence.*

1. Suppose that  $C = \{u_1, \dots, u_k\}$  is a vertex cover of  $G$  of size  $k$ . We can construct a Hamiltonian cycle that encodes  $C$  as follows.

2. Suppose that  $H$  contains a Hamiltonian cycle  $C$ . This cycle must contain an edge from each cover vertex to the start of some vertex chain.

#### Example 10.4 (Reduction from Vertex Cover to Directed Hamiltonian Cycle)

We can see that each double arrowed blue segment represents a pair of directed edges, each part of the gadget.

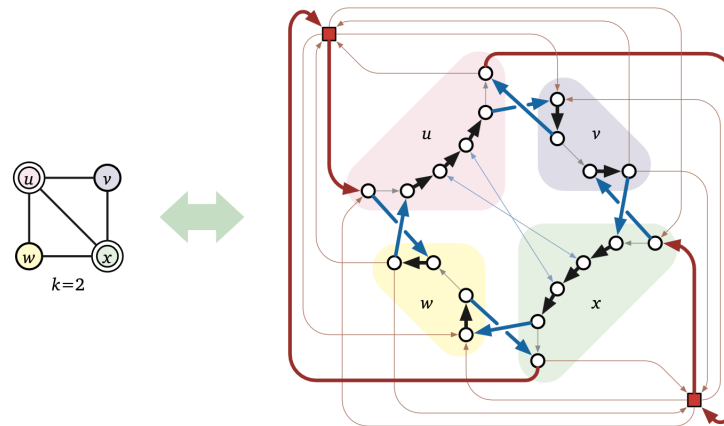

Figure 56: Reduction of a simple undirected graph to Hamiltonian cycle.

#### 10.4.5 Euler Paths

#### 10.4.6 Longest Path

##### Theorem 10.11 (Longest Path)

Finding the longest path in a graph is NP-complete.

#### 10.4.7 Graph Coloring

##### Definition 10.14 (Proper K-coloring)

A **proper k-coloring** of a graph  $G(V, E)$  is a function  $C : V \rightarrow \{1, \dots, k\}$  that assigns one of  $k$  colors to each vertex, so that every edge has two different colors at its endpoints.

##### Theorem 10.12

Graph coloring is NP-hard.

*Proof. Reduction from 3SAT.*

## 10.5 Subset Sum

### Definition 10.15 (Subset Sum)

Given a multiset (allowing duplicates)  $X$  of positive integers and a target value  $T$ , we want to find whether there exists a subset  $S \subset X$  that sum up to  $T$ .

### Theorem 10.13

Finding the subset sum is NP-hard.

*Proof. Reduction from MVC.* Given an arbitrary graph  $G$  and integer  $K$ , we need to compute a set  $X$  of positive integers and integer  $T$ , such that  $X$  has a subset of sum  $T$  iff  $G$  has a vertex cover of size  $K$ . The general idea is that we label each edge with a number in  $\{0, 1, 2, 3\}$ , where 2 means that the edge is in the vertex cover.

1. We label each edge of  $G$  from  $e = 0, 1, \dots, E - 1$ .
2. Construct  $X = \{\}$ :
3. for each  $e = 0, \dots, E - 1$ , add  $b_e = 4^e$  to  $X$ .
4. for each vertex  $v$ , add

$$a_v = 4^E + \sum_{e \in \Delta(v)} 4^e \quad (177)$$

to  $X$ , where  $\Delta(u)$  are the incident edges of  $u$ . What we have just done is represented each integer in  $X$  as an  $(E + 1)$  digit number written in base 4. The  $E$ th digit is 1 if the integer represents a vertex and 0 otherwise. For each  $e < E$ , the  $e$ th digit is 1 if the integer represents edge  $e$  or one of its endpoints, and 0 otherwise.

5. We set our target sum to be

$$T = K \cdot 4^E + \sum_{e=0}^{E-1} 2 \cdot 4^e \quad (178)$$

where the first term covers all vertices and the summation covers all edges.

*Equivalence.*

1. Suppose  $G$  has a vertex cover  $C$  of size  $k$ . Consider the subset

$$X' = \{a_v \mid v \in C\} \cup \{b_e \mid \text{edge } e \text{ has exactly 1 endpoint in } C\} \quad (179)$$

The sum of the elements in  $X'$ , written in base 4, has most significant digit  $k$  and all other digits equal to 2. Thus the elements of  $X'$  sum exactly to  $T$ .

2. Suppose that there is a subset  $X' \subset X$  that sums to  $T$ . We must have

$$\sum_{v \in V'} a_v + \sum_{e \in E'} b_e = T \quad (180)$$

for some subset  $V' \subset V, E' \subset E$ . Then each  $b_e$  contributes exactly one digit of 1 (in base 4). Each edge is incident to 2 vertices, so the non-significant digits contribute two digits of 1. Therefore, if we sum these base-4 numbers, there are no carries in the first non-sigf  $E$  digits since for each  $e$  there are only 3 numbers in  $X$  whose  $e$ th digit is 1. Each edge number  $b_e$  contribute only one 1 to the  $e$ th digit of the sum, but the  $e$ th digit of  $T$  is 2. Thus, for each edge in  $G$ , at least one of its endpoints must be in  $V'$ . In other words,  $V'$  is a vertex cover.

**Example 10.5 (Reduction from Vertex Cover to Subset Sum)**

Given the 4 vertex graph  $G$  with  $V = \{u, v, w, x\}$  and  $E = \{uv, uw, vw, vx, wx\}$ , our set  $X$  will contain the following base-4 integers.

$$\begin{array}{ll} a_u := 111000_4 = 1344 & b_{uv} := 010000_4 = 256 \\ a_v := 110110_4 = 1300 & b_{uw} := 001000_4 = 64 \\ a_w := 101101_4 = 1105 & b_{vw} := 000100_4 = 16 \\ a_x := 100011_4 = 1029 & b_{vx} := 000010_4 = 4 \\ & b_{wx} := 000001_4 = 1 \end{array}$$

We can see that all the  $a$ 's have most significant digit 1, meaning that it represents a vertex, and all the  $b$ 's that represent an edge are simply stored with a single 1 and rest 0s. For the  $a$ 's, the non-significant digits represent the incident edges. Vertex  $u$  has connections to  $v, w$ , so the next 2 bits, representing the 1 bits for edges  $uv, uw$  are flipped to 1. If we are looking for a vertex cover of size  $K = 2$ , we have

$$T = 222222_4 = 2730 \tag{181}$$

Indeed the vertex cover  $\{v, w\}$  corresponds to the subset  $\{a_v, a_w, b_{uv}, b_{uw}, b_{vx}, b_{wx}\}$ , whose sum is  $1300 + 1105 + 256 + 64 + 4 + 1 = 2730$ .

## 11 Streaming Algorithms

### Algorithm 11.0 (Track Median From Data Stream)

---

#### Algorithm 20 Track Median From Data Stream

---

<b>Require:</b> Stream of numbers	▷Input is a continuous stream of numbers
<b>Ensure:</b> Current median after each number	▷Returns median as each number arrives
1: maxHeap ← empty max heap	▷Stores lower half of numbers
2: minHeap ← empty min heap	▷Stores upper half of numbers
3: <b>function</b> ADDNUMBER(num)	
4: <b>if</b> maxHeap.isEmpty() OR num < maxHeap.peak() <b>then</b>	▷Number belongs in lower half
5:     maxHeap.add(num)	▷Add to max heap
6: <b>else</b>	
7:     minHeap.add(num)	▷Add to min heap
8: <b>end if</b>	
9:   balance ← maxHeap.size() - minHeap.size()	▷Check heap balance
10: <b>if</b> balance > 1 <b>then</b>	▷Max heap has too many elements
11:     minHeap.add(maxHeap.poll())	▷Move largest from max heap to min heap
12: <b>else if</b> balance < -1 <b>then</b>	▷Min heap has too many elements
13:     maxHeap.add(minHeap.poll())	▷Move smallest from min heap to max heap
14: <b>end if</b>	
15: <b>end function</b>	
16: <b>function</b> FINDMEDIAN	
17: <b>if</b> maxHeap.size() > minHeap.size() <b>then</b>	▷Odd number of elements
18: <b>return</b> maxHeap.peak()	▷Return top of max heap
19: <b>else if</b> minHeap.size() > maxHeap.size() <b>then</b>	▷Odd number of elements
20: <b>return</b> minHeap.peak()	▷Return top of min heap
21: <b>else</b>	▷Even number of elements
22: <b>return</b> (maxHeap.peak() + minHeap.peak()) / 2	▷Average of both tops
23: <b>end if</b>	
24: <b>end function</b>	

---

## 12 Linear Programming

Basically, you want to solve a constrained optimization problem. Some examples are

1. Shortest path: select a set of edges of minimum cost such that  $s$  and  $t$  are connected.
2. Minimum Spanning Tree: select a set of edges of minimum cost such that all vertices are connected.
3. Maximum Flow: select a flow on every edge such that capacity and balance constraints are respected.

### Definition 12.1 (Linear Programming)

In linear programming both the constraints and optimization objectives are linear functions. It is usually written in *canonical form*, of the form

$$\min c^T x \text{ subject to } Ax \geq b, x \geq 0 \quad (182)$$

or

$$\max c^T x \text{ subject to } Ax \leq b, x \geq 0 \quad (183)$$

where we have  $n$  variables  $x \in \mathbb{R}^n$ ,  $c \in \mathbb{R}^n$  are the optimization coefficients, and  $A \in \mathbb{R}^{m \times n}$  are the matrix of  $m$  constraint equations.

### Example 12.1 (Simple LP)

We can have the problem of maximizing  $2x + y$  subject to

$$x + y \leq 1 \quad (184)$$

$$x \geq 0 \quad (185)$$

$$y \geq 0 \quad (186)$$

In this case, we can write it in canonical form as

$$\max (2 \ 1) \begin{pmatrix} x \\ y \end{pmatrix} \text{ subject to } (1 \ 1) \begin{pmatrix} x \\ y \end{pmatrix} \leq 1, \begin{pmatrix} x \\ y \end{pmatrix} \geq \begin{pmatrix} 0 \\ 0 \end{pmatrix} \quad (187)$$

### Theorem 12.1 (Optimality of LP)

An optimal solution to a linear program can be obtained in weakly polynomial time in the number of variables, constraints, and poly-logarithmic in the constants in the LP.<sup>a</sup>

<sup>a</sup>Obtaining a strongly polynomial algorithm for LPs remains a major open problem.

This is very similar to integer programs, which solve for integer solutions rather than real, but in general we don't know of algorithms that can solve integer programs in polynomial time. However, integer programs can be "relaxed" to linear programs by removing the restriction on variables being integers. However, the optimal solution for the relaxed LP may be different from that of the original LP.

### Example 12.2 (Max Flow as LP)

**Example 12.3 (Bipartite Matching as LP)****Example 12.4 (Primal vs Dual LP)**

Now given a maximization LP problem, such as

$$\max 2x + y \text{ subject to } \begin{cases} x + y \leq 3 \\ x - y \leq 1 \\ x, y \geq 0 \end{cases} \quad (188)$$

we can just find *one* solution satisfying the constraints and use it as a lower bound on the optimum. Say we find one, e.g.  $x = y = 0$ , which does satisfy all constraints. Now if we want to find an *upper bound* on the value of the solution, we can use duality. We create new variables  $a, b \geq 0$ , and observe that

$$x + y \leq 3 \implies a(x + y) \leq 3a \quad (189)$$

$$x - y \leq 1 \implies b(x - y) \leq b \quad (190)$$

Thus by adding the two we have  $(a + b)x + (a - b)y \leq 3a + b$ .

Now if we suppose  $a + b \geq 2$  and  $a - b \geq 1$  (which are the coefficients of  $2x + y$ ), then since  $x, y \geq 0$ , we have

$$2x + y \leq (a + b)x + (a - b)y \leq 3a + b \quad (191)$$

so any  $a, b$  satisfying the above inequalities give an upper bound of  $3a + b$  on the value of the optimal solution. Say we have  $a = 2, b = 1$ , which does satisfy. Then  $3a + b = 7$  is an upper bound of  $2x + y$ . Therefore, to get the tightest upper bound, we can minimize the dual problem

$$\min 3a + b \text{ subject to } \begin{cases} a + b \geq 2 \\ a - b \geq 1 \\ a, b \geq 0 \end{cases} \quad (192)$$

This is called the **dual LP**.

Generally, given the primal  $\max c^T x$  subject to  $Ax \leq b$  and  $x \geq 0$ , the dual problem is to compute  $\min b^T y$  subject to  $A^T y \geq c$  and  $y \geq 0$ . Every dual variable corresponds to a primal constraint and vice versa. If a primal has  $n$  variables and  $m$  constraints, the dual has  $m$  variables and  $n$  constraints.

**Theorem 12.2**

The dual of a dual is the primal.

**Theorem 12.3 (Weak Duality)**

The following properties are called **weak duality**.

1. The optimal value for a dual maximization LP is a lower bound on the optimal value for a primal minimization LP.
2. The optimal value for a dual minimization LP is an upper bound on the optimal value for a primal maximization LP.

**Theorem 12.4 (Strong Duality)**

The optimal value of a primal and dual LP are exactly identical, called **strong duality**.

**Example 12.5 (Vertex Cover)**

You are given an undirected graph  $G = (V, E)$ . A vertex cover is a subset of vertices  $S \subseteq V$  such that every edge in  $E$  has at least one endpoint in  $S$ . That is, for each edge  $(u, v) \in E$ , either  $u \in S$  or  $v \in S$  (or both). The size of a vertex cover  $S$  is the number of vertices in  $S$ ,  $|S|$ . The minimum vertex cover is the vertex cover with the minimum size.

1. Write an integer program to compute the minimum vertex cover in  $G$ . Clearly define all variables and provide a brief English explanation of the objective and each constraint.
2. Relax your program from part *a* to a linear program, and take its dual. Interpret your result as another algorithmic optimization problem.

The relaxed primal LP problem is finding

$$\min \sum_{v \in V} x_v \text{ subject to } \begin{cases} x_u + x_v \geq 1 & \text{for all } (u, v) \in E \\ x_u \geq 0 & \text{for all } u \in V \end{cases} \quad (193)$$

To introduce the dual problem, we can introduce the variables for each edge  $x_{uv} \geq 0$ . Therefore, we can take each constraint  $x_u + x_v \geq 1$  and multiply it by  $x_{uv}$  to get  $x_{uv}(x_u + x_v) \geq x_{uv}$  for all  $(u, v) \in E$ . Therefore, summing it up, we get

$$\sum_{(u,v) \in E} x_{uv}(x_u + x_v) \geq \sum_{(u,v) \in E} x_{uv} \quad (194)$$

Now we rephrase the left summation. Summing over all edges is the same as summing over all nodes, and for each node summing over all adjacent edges to that node, and so we can get

$$\sum_{v \in V} \left( \sum_{(u,v) \in E} x_{uv} \right) x_v \geq \sum_{(u,v) \in E} x_{uv} \quad (195)$$

To make the LHS a lower bound of  $\sum_{v \in V} x_v$ , we can introduce the constraints that all coefficients are  $\leq 1$ , so we have the dual constraints

$$\sum_{(u,v)} x_{uv} \leq 1 \text{ for all } v \in V \quad (196)$$

Since  $\sum_{(u,v) \in E} x_{uv}$  is a lower bound, we want to maximize the lower bound and so our dual optimization problem is

$$\max \sum_{(u,v) \in E} x_{uv} \quad (197)$$